



King's Research Portal

DOI:

[10.1109/COMST.2018.2851452](https://doi.org/10.1109/COMST.2018.2851452)

Document Version

Peer reviewed version

[Link to publication record in King's Research Portal](#)

Citation for published version (APA):

Antonakoglou, K., Xu, X., Steinbach, E., Mahmoodi, T., & Dohler, M. (2018). Towards Haptic Communications over the 5G Tactile Internet. *Ieee Communications Surveys And Tutorials*, 1-27.
<https://doi.org/10.1109/COMST.2018.2851452>

Citing this paper

Please note that where the full-text provided on King's Research Portal is the Author Accepted Manuscript or Post-Print version this may differ from the final Published version. If citing, it is advised that you check and use the publisher's definitive version for pagination, volume/issue, and date of publication details. And where the final published version is provided on the Research Portal, if citing you are again advised to check the publisher's website for any subsequent corrections.

General rights

Copyright and moral rights for the publications made accessible in the Research Portal are retained by the authors and/or other copyright owners and it is a condition of accessing publications that users recognize and abide by the legal requirements associated with these rights.

- Users may download and print one copy of any publication from the Research Portal for the purpose of private study or research.
- You may not further distribute the material or use it for any profit-making activity or commercial gain
- You may freely distribute the URL identifying the publication in the Research Portal

Take down policy

If you believe that this document breaches copyright please contact librarypure@kcl.ac.uk providing details, and we will remove access to the work immediately and investigate your claim.

Towards Haptic Communications over the 5G Tactile Internet

Konstantinos Antonakoglou¹, Xiao Xu², Eckehard Steinbach², Toktam Mahmoodi¹, Mischa Dohler¹

¹Centre for Telecommunications Research, King's College London

²Chair of Media Technology, Technical University of Munich

Touch is currently seen as the modality that will complement audition and vision as a third media stream over the Internet in a variety of future haptic applications which will allow full immersion and that will, in many ways, impact society. Nevertheless, the high requirements of these applications demand networks which allow ultra-reliable and low-latency communication (URLLC) for the challenging task of applying the required Quality of Service (QoS) for maintaining the user's Quality of Experience (QoE) at optimum levels. In this survey, we enlist, discuss and evaluate methodologies and technologies of the necessary infrastructure for haptic communication. Furthermore, we focus on how the fifth generation (5G) of mobile networks will allow haptic applications to take life, in combination with the haptic data communication protocols, bilateral teleoperation control schemes and haptic data processing needed. Finally, we state the lessons learned throughout the surveyed research material along with the future challenges and infer our conclusions.

Index Terms—Tactile Internet, 5G, haptic communication, bilateral teleoperation, haptic data reduction, multi-modal media networks

I. INTRODUCTION

GREAT part of ongoing research on the fifth generation of mobile networks (5G) is focused on meeting the requirements of the *Tactile Internet* [1]–[3]. A major design challenge here is to provide ultra-low delay communication over the network which would enable real-time interactions across wireless networks. This, in turn, will empower people to wirelessly control both real and virtual objects. It will undoubtedly add a new dimension to human-machine interaction and lead to an unprecedented revolution in almost every segment of society with applications and use cases like mobile augmented video content, road traffic/autonomous driving, healthcare, smart grid, remote education, and remote immersion/interaction among others [1].

One specific application domain of the Tactile Internet is teleoperation which allows for remote immersion, including remote touch. Traditional remote interaction solutions such as voice or video conferencing, remote teaching, etc., have reached a high level of sophistication and widespread use thanks to the growth and progress of audio-visual communications.

With the benefits of this technology, users experience an improved virtual presence, immersing in a remote environment. With current advances in communication infrastructure, it has been foreseen that in the near future, a complete remote immersion can be realized with the ability of physical interaction with the remote environment. This is achieved by the exchange of multi-modal information, such as the combination of audio, video and haptic information, over the Internet. Such immersion will be feasible for commercially acceptable use, with real-time applications such as teleoperation with haptic feedback (referred to as teleoperation) or haptic data broadcasting in virtual environments [4].

Haptics refer to both kinesthetic perception (information of forces, torques, position, velocity, etc. sensed by the muscles, joints, and tendons of the body) and tactile perception (in-

formation of surface texture, friction, etc. sensed by different types of mechanoreceptors in the skin) [5]. It must be noted that the previously mentioned term "tactile" refers to its literal meaning, i.e. the human perception of touch. When used in the term "Tactile Internet", it signifies the feature of ultra-low delay communication over the Internet which is a necessity for many 5G use cases including haptic communication. As one of the applications of the Tactile Internet, haptic communication using networked teleoperation systems has specific requirements, the most demanding being the efficient and timely exchange of kinesthetic or tactile information while synchronously providing the user with auditory and visual information.

Different from the communication of audio and video signals, haptic signals in bilateral teleoperation systems are bidirectionally exchanged over the network. It involves human users and closes a global control loop between the human users and the actuators/teleoperators. Thus, system stability and teleoperation quality are very sensitive to communication delay [6].

Use cases of the Tactile Internet, which highlight its importance, can be found in the medical, industrial, education and entertainment sectors. These include remote medical examination or surgery, industrial teleoperation in e.g. construction sites, mines or factories, tele-mentoring and gaming to name a few. The benefits of the realization of the Tactile Internet will revolutionize our way of living and increase the safety and efficiency of various tasks. Nonetheless, there are hindrances to be overcome and the previously mentioned requirements to be met.

Concepts and technologies around the Internet of Things (IoT), 5G and the Tactile internet overlap each other, as indicated in [7], requiring very low latency and high reliability communication channels, high-bandwidth low-latency and secure infrastructure as well as bringing the intelligence of the network closer to the edge of the network.

As described in [8], one of the challenges in 5G mobile

networks development is the provision of low-latency communications with acceptable Quality of Experience (QoE) for the users. Since evaluating QoE in haptic-based applications with force feedback over the Internet is a process that has only recently taken its first steps, the way to resolve this open issue is still under investigation.

The delay requirements of haptic communication for networked teleoperation systems are heavily dependent on the application scenarios. Taking into account the latest achievements on haptic communication, as illustrated in Figure 1, the less dynamic the remote environment, the more the interaction between a user and the remote environment is increased. Consequently, different application scenarios arise in accordance with each level of dynamics and the corresponding range of time delay that is considered as acceptable for feasible interaction.

Applications which can tolerate delays over 1ms are within the scope of teleoperation (the blue circle of Figure 1); a broad range of applications that can be divided into three categories of teleoperation, wherein each scenario is associated to a level of dynamics of the remote environment the user is interacting with and the corresponding delay tolerance. This leads to teleoperation applications with different degrees of immersive perception that range from space teleoperation to remote steering of automobiles, demonstrating different levels of abstraction between the user and the remote environment.

The case of highly dynamic environments, where a latency of under 1ms is needed, is out of the scope of teleoperation as only control systems can undertake the completion of tasks with such latency requirements because humans are underqualified for this kind of interaction. Specifically, for completing such tasks high *Quality of Control* (QoC) is needed. Examples would be a magnetic levitation system that keeps a running train floating in midair, a fully automatic driving system that precisely platoons vehicles and zips the vehicles through intersections without traffic lights, or a real-time simultaneous localization and mapping (SLAM) with autonomous-controlled cameras [9]. As a result, these cases will not be examined in this survey.

On the other hand, in this survey we focus on the efforts for haptic communication in networked teleoperation systems over the Tactile Internet and examine in detail the advancements in teleoperation over long distances. Three main domains for enabling teleoperation over global connectivity are studied here, including: (i) the communication network from the perspective of providing reliable (guaranteed) low-latency communications, (ii) intelligent data processing to compensate for the communication latency and for reducing bandwidth usage, and finally (iii) stability control schemes implemented at the teleoperation devices to reduce the impact of potential latency. The focus of this study is on remote environments of low and intermediate dynamics (red text in Figure 1). Within this range of dynamics there is a variety of applications such as remote surgery (low dynamics) or collaboration of users in virtual or real environments (intermediate dynamics).

The structure of this survey is as follows: In Section II we describe teleoperation systems in detail, classify and describe the challenges behind bilateral teleoperation systems

and elaborate on a number of commercially popular haptic devices. Section III is concerned with how network-based teleoperation systems communicate over the Internet, data stream management for the audio, video and haptic data streams, with special interest to network protocols of the transport and application layer. It also includes common network performance parameters and elaborates on provisioning of QoS in the network. Additionally, we briefly discuss network security. Next, Section IV covers a range of methodologies and frameworks for reducing the quantity of haptic data to be transmitted through a communication channel. In Section V we refer to the main and also most recent teleoperation bilateral control approaches, mainly focusing on passivity-based approaches but also mentioning other approaches not based on passivity. The approaches we will focus on can be combined with haptic data reduction methods to provide high QoE to the user. Moreover, Section VI presents the latest developments on 5G mobile infrastructure and technologies with focus on ultra-reliable low-latency communication as well as the main KPIs of various 5G use cases. Section VII discusses the lessons learned from this survey and outlines future research directions as well as the current challenges of haptic communication over the 5G networking infrastructure. Finally, in Section VIII we infer the conclusions.

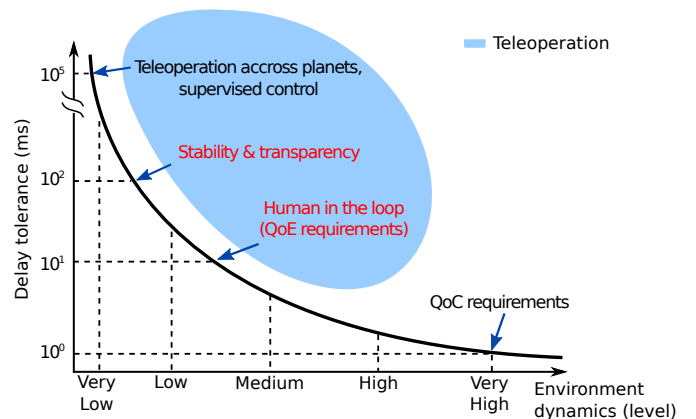

Figure 1. Delay requirements on different applications of immersive perception

II. TELEOPERATION

Multi-modal *telepresence* and *teleaction* (TPTA) systems for haptic telemanipulation, also known as *telehaptic* systems [10], usually consist of one human operator using a haptic interface (master device) on one end, a communication channel and one teleoperator (slave actuator) on the other end (Figure 2). For short distance applications the communication channel can be a direct wired or wireless communication channel without the need for network infrastructure. On the other hand, long distance applications benefit from packet-switched network infrastructures, and transmit their data as packets. The scale of long distance applications can range from teleoperation over local area networks to teleoperation over the Internet.

The goal of TPTA systems, as implied by their name, is to provide to the user the feeling of presence in the remote

environment where the teleoperator exists. It is a goal which can be achieved due to the ongoing improvement of the relevant hardware and software for providing the human users with multi-modal (visual, auditory, and haptic) feedback.

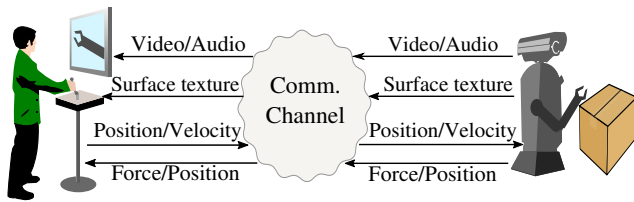

Figure 2. An example of a haptic communication system. In this case, the master device (user) sends position and/or velocity data while the slave device (robot) transmits the haptic feedback data, audio and video data streams.

A. Classification of teleoperation systems

Nowadays, extensive research has been made in bilateral and multilateral telehaptic systems [11], [12]. An approach for classifying teleoperation systems can be based on the different communication delays and interaction levels a user may experience and results in two main categories, *Direct control* systems and *Supervisory control* systems as described in [13]. As shown in Figure 3, we subdivide each of these categories further into subcategories:

- 1) *Direct control*: The human operator interacts in real-time with the environment while the master and slave devices communicate using position/force signals.
 - a) *Closed-loop with negligible delay*: In this case, the communication channel presents minimum delay and therefore the user is restricted to be in close proximity to the slave device.
 - b) *Time-delayed closed loop*: The most common form of teleoperation for digital closed-loop control systems. Similarly to the previous subcategory, the master device controls the slave actuator but the user is less restricted in terms of distance from the device (e.g. transatlantic teleoperation). The remote side is not autonomous, however, an internal control loop which processes the command signals from the master device is included in the teleoperator. In this case, the communication channel (e.g. the Internet), may introduce variable delays [6].
- 2) *Supervisory control*: The teleoperator is a) autonomously or b) semi-autonomously controlled and receives high-level commands from the master. It is also referred to as task-based teleoperation. Examples are teleoperation across planets or teleoperated robots with autonomous functionalities [14].

B. Master and slave subsystems

Typically, at the master subsystem of a haptic bilateral communication system, a human operator interacts with a haptic interface which uses sensors and transmits motion data (position or velocity data which are previously packetized) over a communication channel, to the slave subsystem. In

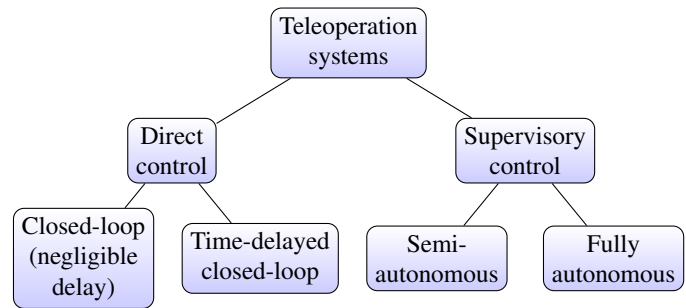

Figure 3. A classification of teleoperation systems

return, the latter will respond with the force reflection/feedback of the remote environment, in the form of kinesthetic or vibrotactile force feedback data [12] while in some cases, such as in the concept of virtual fixture, position data may also be transmitted.

Haptic devices which are used as master teleoperation interfaces, also called haptic manipulators, are comprised of actuators and sensors which form the kinesthetic and tactile device subsystems. Such haptic devices may be able to reproduce and process kinesthetic (kinesthetic interfaces), tactile (tactile interfaces) or both types of haptic data (haptic interfaces). Such devices have been created either as commercially available products or prototypes for academic research.

In [15] the authors discuss the topic of haptic devices and haptic actuators in relation to haptic communication over the Tactile Internet, making the important point that there is a need for ungrounded haptic devices with which the user does not need to stay in a specific area, contrary to the current state of haptic devices which are grounded. A list of hand-held kinesthetic devices as well as a performance evaluation was presented in [16]. As stated the most popular haptic interface is the Geomagic Touch (formerly known as Phantom Omni). These devices present specific technical characteristics such as the Degrees-of-Freedom (DoF) they support (either for sensing position or exerting force), the maximum force or torque they can output, the usable space they can operate in and their rotation capabilities (if their DoF specification allows them).

Many haptic interfaces, such as CyberGrasp [17] (an exoskeleton device), may also be entirely wearable or have wearable components in order to provide tactile feedback more effectively. It is possible to use more than one actuator for each finger. A variety of such interfaces are called tactile displays and make use of tactile actuator arrays using various technologies. Examples of such tactile devices are TPad [18], which is applied to the screen of mobile phones and Gloveone [19], a glove that provides tactile feedback to the fingers and palm.

The hardware design parameters of haptic devices (e.g. sampling frequency) and the number and type of sensors and actuators determine the amount of data the device will output or needs as input. They also determine the limitations of the interaction between a user or an object and the device. A recent detailed review of tactile sensors has been made in [20].

The slave haptic subsystem can be either a physical device

which interacts with a physical remote environment or a virtual pointer of any form (e.g. a virtual hand) that operates in a virtual environment. A key difference between physical and virtual environments is that the control laws that govern a physical environment are of continuous nature whereas a virtual is of discrete nature. Virtual environments, even though it is not feasible to perfectly replicate a physical environment, have the advantage of allowing, in some cases, the interaction among multiple users to interact with each other in a virtual space over a local network or the Internet. By employing the tactile or kinesthetic modalities these systems are called *Collaborative-Haptic Virtual Environments* (C-HAVE) [21].

C. Challenges of teleoperation systems

Communication of haptic information for teleoperation systems imposes strong demands on the communication network. This presents two main challenges for designing a reliable teleoperation system.

First, haptic sensor readings from kinesthetic devices are typically sampled, packetized and transmitted at a rate of 1 kHz or even higher [6], [22], [23] to maintain stability and transparency of the system (further discussed in V-B). It must be noted that this is not a strict requirement, however, according to the stability analysis in [24]–[26] there is a relationship between the sampling rate, the maximum displayed stiffness and the system damping for ensuring system stability. A teleoperation system operating with lower values of sampling rate may still work and the user may be able to complete a task. Nonetheless, the maximum displayed stiffness, while guaranteeing system stability, is smaller than that of a higher sampling rate and therefore the system may require larger damping for stabilizing a hard contact.

Communication of kinesthetic information for teleoperation systems, hence, requires a thousand or more haptic data packets per second to be transmitted between the master and the slave devices. Such a high packet rate may lead to the consumption of a large amount of network resources in combination with the transmission of audio and video data and leads to inefficient data communication (see Section IV). Therefore, haptic data reduction, or packet rate reduction, is required in teleoperation systems. Moreover, tactile information, especially in the form of complicated texture surfaces, requires data compression.

Second, teleoperation systems are very sensitive to data loss and latency [6]. Concerning the latter, a haptic communication system device usually needs to transmit and receive a packet every millisecond, otherwise stability cannot be guaranteed. Consequently, an important question can be raised concerning the amount of latency compared to the amount of data loss that a system can tolerate. As it has been shown in [27] a 90% reduction can be attained, whereas even a small amount of delay can disrupt the stability of a bilateral teleoperation system. Even for a small communication delay or packet loss rate, teleoperation systems may show stability issues making degradation of teleoperation quality and task performance. With the introduction of a communication channel such as the Internet over mobile networks, this issue is inevitable.

Therefore, to guarantee system stability and improve *Quality of Task* (QoT) performance is a key objective of telemanipulation systems [28], [29]. Quality of Task, presents the quality of task performance and is usually quantified by measuring the task completion time due to simplicity. Additionally, other performance measures are the sum of squared forces (SOSF), peak forces, task error/failure rate, the haptic device trajectory, range of motion and velocity [30].

On the other hand, this also implies that the network infrastructure itself, if improved to the point of meeting all requirements, should be able provide adequate resources and quality of communication for the best possible QoE and decrease the dependence to altering haptic information.

In addition, haptic communication systems usually need to provide to the user visual and audio feedback from the slave subsystem. High packet rate, packet loss and variable delay can cause the management and synchronization of the data streams to become a challenging problem. In this case, packet-switched network frameworks and protocols are needed for synchronizing the data streams [31], for measuring the network conditions and managing the Quality of Service [32].

Summing up, we detail three main solution spaces to improve haptic communication:

- The *communication network* solution space covering both aspects of the Internet and the mobile/wireless communication that enables the Tactile Internet.
- *Data processing* solutions to reduce data transmission using perceptual thresholds or prediction methods in order to compensate the incurred delay by long distance communications.
- *Stability control* solutions to reduce the effect of extra delay and provide stability for the control loop.

Improvements in all solution spaces of haptic communication are under development and research. Main contributions to these solution spaces will be presented in the next chapters. Individual or joint improvement of the communication channel, control components and signal processing will guarantee high teleoperation quality, system stability and scalability. While current research studies address mainly these solution spaces independently (few studies address two of these spaces jointly), the ultimate solution for enabling the haptic communication should be based on joint optimization of these three solution spaces. A discussion of future challenges on haptic communication over 5G exists in Section VII.

III. HAPTIC COMMUNICATION OVER THE INTERNET

With the increase of mobile Internet-enabled machines and devices over the world, mobile networks play an important role as the medium for the transmission and reception of data. In comparison to other networks, the more complex mobile network infrastructure inevitably introduces latency into any communication system.

Since using the Internet over a mobile network as a communication channel can be responsible for most of the time the transmitted information will be delayed, finding ways to reduce this delay is inevitable. In this way, system stability and transparency will be easier to maintain.

In this section, we will first discuss the fundamental networking infrastructure that has already been used for haptic communication over networks, focusing on network protocols of the transport and application layers as well as frameworks for the synchronization of multi-sensorial data streams. Furthermore, we will mention the efforts on security for teleoperation and also the parts of 5G infrastructure relevant to haptic communication.

A. Haptic Communication Protocols and Frameworks

Internet-based TPTA systems implement closed-loop control schemes over a real-time communication framework that allows interaction between a human operator and a remote environment using sensors and actuators. A system which can be described in this way is referred to as *networked-based control system* (NBCS) [33].

Since one of the core modules of such systems is the communication channel, several network protocols have been used or created for all teleoperation frameworks mentioned in previous chapters and their implementations over the Internet, supporting their efficient functionality either for virtual environment applications [34] or physical systems.

As with every networking system, the correct functionality of NBCS is liable to several obstacles which negatively affect their performance and can also be viewed as performance indicators which allow the comparison between different protocols and the quantification of the *Quality of Service* (QoS) they can deliver which is of critical importance to applications such as telesurgery. Considering that teleoperation systems are NBCSs, it is natural to inherit these performance aspects with respect to requirements of TPTA systems. Common performance parameters [35]:

- *Network delay* is the average time needed for a packet to travel from the input of the communication channel to its output. A survey that thoroughly lists and discusses the main sources of network delay as well as the solutions that can be currently implemented is [36].
- *Jitter* is the result of the influence delay has to packets independently, formally known as Packet Delay Variation (PDV) which affects the packet sequence. A common way to avoid jitter is to use packets with sequence numbers or timestamps, nonetheless this presumes the use of buffers which in turn will increase the overall delay of the communication.
- *Packet loss* is a consequence of the network traffic congestion. As a result, the master and slave side of a TPTA system need to operate even with lack of information due to missing packets. Ways to overcome packet loss are substituting the missing values with null values, hold the last value or use interpolation (e.g. using a prediction method).
- *Data rate* of the communication channel. This can be affected by the sampling frequency, the sample resolution and the protocol overhead.

Additionally, alternative factors that may affect the system performance are signal quantization and other sources of noise.

The effects of packet loss with and without latency in discriminating visual and haptic events, although primarily focusing on packet loss, in the communication channel have been explored in [37] showing that both factors have an additive behaviour. Nonetheless, according to [38] the effects of packet loss can be managed by using mechanism which increase the communication reliability, but, as a result these mechanisms will increase the total latency. It is therefore a matter of balancing the trade-off between reliability and delay.

A detailed description of QoS control methods has been given in [39], referring to traffic management, flow control, error control, Δ -causality control, other types of control and last but not least the aspect of synchronization of media streams. It is worth to mention that the authors of the paper also specify methods for estimating QoE. All protocols try to satisfy the aforementioned QoS requirements and therefore encompass characteristics and mechanisms, such as QoS control methods that focus on haptic data stream or also take the other modalities (sound, video) into account, towards a reliable but also transparent haptic communication. A list of these characteristics has been defined in [40].

Network-based control haptic systems (NCHS) can be divided into two main classes: those that implement the client-server architecture and those that implement a peer-to-peer one, the latter being the most popular choice due to its support to parallel computation, scalability and also being less sensitive to negative networking conditions.

Despite the recent advances in telecommunication infrastructure, choosing a communication protocol for a teleoperation system needs thinking of how the network conditions might affect haptic applications, as some tasks have higher requirements than others in order to provide high QoE. With respect to the Internet protocol suite networking model, transport and application layer protocols have mainly been developed [40]. Nonetheless, network layer solutions, such as the DiffServ architecture [41] and different network coding strategies have also been examined, both concepts are discussed later on in this survey in this section and in section VI respectively. Of course other approaches, also mentioned later on, are taking the 7-layered Open Systems Interconnection (OSI) model into account.

1) Transport layer

In the transport layer, the most common protocols used in the research literature for haptic communication over the Internet are the TCP and UDP protocols. Even so, other protocols have been developed in pursuance of keeping the system stable and for effectively reaching greater transparency. These protocols have either been tested for the physical interaction between human operators and remote environments or have been used for communication between physical devices and virtual environments that allows the manipulation of virtual objects.

According to [42], a survey made in 2012, a total of ten different transport and application layer protocols are reported. Since then, other protocols have emerged as well. Other sources [43] can be used to extend the list of the survey with other protocols as well.

Iterating through the previously mentioned performance parameters, we can classify existing protocols according to the parameter or parameters they try to optimally improve.

For minimizing the effects of jitter, TCP is the best candidate, however, TCP's mechanisms responsible for such reliable data transmission, also prevent it from being used as a real-time protocol. Evidently, it is the least suitable protocol for haptic communication applications. A modified version of TCP with *Nagle Algorithm Invalidation* [44] avoids one of TCP's mechanisms in which the sender must continue buffering if the receiver's capacity capabilities are exceeded, until the Maximum Segment Size (MSS) is reached by the accumulated packets. This mechanism was introduced to avoid congestion over slow links, but by avoiding it time delays are decreased.

Regarding the minimization of network delay, the most suitable protocol is UDP. Nonetheless, UDP's simplicity does not meet the reliability requirements of most haptic applications especially in networks under packet congestion. A more suitable solution that is built on UDP, the *Smoothed Synchronous Collaboration Transport Protocol* is mainly used in haptic virtual environment applications [45] as its predecessor SCTP and attempts to deal with jitter by employing a buffer at the receiver and handling packets according to a timestamp placed at the header of each packet. This method results in a fixed delay for all messages. Smoothed SCTP should not be confused with S-SCTP which stands for Secure SCTP.

Apart from dealing with jitter, SCTP, S-SCTP and the *Interactive Real-Time Protocol* (IRTP) [46], also prioritize messages according to their significance. Specifically for IRTP, it establishes a connection same as TCP at first and for transmitting essential data. This makes it a connection-oriented protocol. To transmit less important data, IRTP employs UDP. It also addresses the issue of the non-optimized size of the packet header by proposing a redesigned structure of header fields.

A protocol called *Supermedia TRansport for teleoperations over Overlay Networks* (STRON) [47], was created to operate over overlay networks transmitting data using different network paths. STRON was compared against TCP and SCTP, showing that it performs significantly better in the case of a network that includes paths with heavy packet loss.

Another protocol called *Real-Time Network Protocol* (RTNP), created by Uchimura *et al.*, was developed for use on UNIX environments in order to eliminate time delay caused by the specific multitasking operating system [48], therefore, this protocol cannot be implemented on other platforms. Timely execution of the protocol handler tasks with real-time interrupts allows for more immediate transmission of haptic data packets. Furthermore, the *Efficient Transport Protocol* (ETP) [49], aims to reduce round-trip delay time which is related to the interpacket gap (IPG). By monitoring the transfer rate, it is possible to optimize IPG by setting it to a minimum value in order to maintain stability and maximum performance of the haptic application.

A hybrid solution, a protocol that tries to leverage the advantages of others such as SRM, SRTP, RMTP and SCTP is the *Hybrid Multicast Transport Protocol* (HMTP) [50] and

is mainly used for realizing haptic collaboration in virtual environments.

A comparative evaluation of the performance of these protocols for haptic applications does not exist to the best of our knowledge, therefore it is not possible to conclude about which one would be more suitable. Nonetheless, we understand that with the exception of TCP and UDP which represent maximum reliability and minimum packet header overhead respectively, all other protocols need to balance the trade-off between reliability and latency.

Table I shows a qualitative comparison among the previously discussed protocols. Evidently, all protocols based on UDP inherit UDP's transmission of packets in a connectionless mode in comparison to the ones based on TCP. Three of the protocols listed (ETP, STRON and HMTP) were created as haptics-specific protocols whereas only one of them (HMTP) has been created for the purpose of being used in virtual environments for haptic collaboration. Only HMTP implements a security feature for user authentication when joining a session in a virtual environment.

TABLE I
COMPARISON OF TRANSPORT LAYER PROTOCOLS

	Connectionless	Haptics-specific	Security	Virtual Env. only
TCP	X	X	X	X
UDP	✓	X	X	X
IRTP [46]	X	X	X	X
Smoothed SCTP [45]	✓	X	X	X
STRON [47]	X	✓	X	X
ETP [49]	✓	✓	X	X
HMTP [50]	X	✓	Partial	✓
RTNP [48]	✓	X	X	X

2) Application layer

Apart from only streaming haptic data through the communication channel, as previously described, the QoE requirements demand the synchronized transmission of both audio and video data without leaving the scope of real-time interaction of the haptic interface user with the remote environment. A system that can provide the user with such services is included in the multi-modal or multi-sensorial media (mulsemedia) systems category. In the highest of all layers, an important aspect of the application layer protocols is the aggregation and management of streams of video, audio and haptic data in order to be transported using a single data stream.

Temporal management of the data streams is a key objective of mulsemedia systems in order to provide synchronization of all media. An investigation on how synchronization errors affect mulsemedia systems has been made in [51], [52]. It needs to be noted that in this survey we focus on data streams for the visual, audio and haptic modalities, as some mulsemedia systems in general may also support other modalities and sensations such as scent or air flow (for emulating wind). Furthermore, kinesthetic, tactile, audio and video data are sent in separate data streams. A multiplexing scheme was presented in [31].

Several attempts have been made for synchronizing haptic, video and audio data streams by using different protocols, codecs and procedures for establishing the connection between

two or more communication terminals. After the first stage of packetizing data of each stream, all packets are aggregated in a single stream by a multiplexing unit. Existing frameworks that use application layer protocols and frameworks with such capabilities will be further discussed in the following paragraphs together with other synchronization practices.

A framework for adaptively controlling the data rate of different mulsemmedia streams according to the human perception limits, the Adaptive Mulsemmedia Delivery Solution (*ADAMS*), is based on a client-server architecture. The server consists of several modules that take into account various information sent from the client (e.g. network conditions) and decides on the amount of quality reduction that needs to be made on the multimedia and mulsemmedia data streams [53].

Again, based on the client-server scheme, in [54] haptic communication is achieved by employing the Session Initiation Protocol (SIP) on the application layer in order to establish a teleoperation session and to manage haptic transport streams that use Real-Time Transport Protocol (RTP) which encapsulates the haptic data in UDP packets. In this case, SIP allows for having an abstraction layer in order to incorporate encoded data in the packets using a haptic codec. Another protocol, based on RTP, is the "*RTP for Distributed Interactive Media*" (RTP/I is an application layer protocol focused on media beyond audio and video, as stated in [55]). Therefore, a generic interactive media model that covers the spectrum of interactive media applications in which TPTA applications are included is also introduced. A protocol created to surpass the disadvantages of RTP [56], the *MPEG Media Transport*, is an application layer transport protocol used in [57] for the purpose of multi-modal data transmission on 3D tele-immersion environments (3DTI).

In the multi-modal communication framework of PAHCP [58], which is concerned with C-HAVE applications (not physical ones), data synchronization is implemented using the Network Time Protocol (NTP) while graphics and haptic data are transmitted with Virtual Network Connection (VNC) and PAHCP respectively. PAHCP enables perception-based data reduction implementations. Based on UDP, this protocol is a "modified version of the smoothed SCTP".

Another protocol mainly focused on interactive haptic virtual environments is the *Application Layer Protocol for HAptic Networking* (ALPHAN). ALPHAN is built on top of the UDP for enhancing the latter's characteristics which are unable to meet the high-demanding C-HAVE conditions and exchanges the QoS parameters with the XML-based Haptic Application Meta-Language (HAML) file format [59]. HAML is also used by Admux (Adaptive Multiplexer), a framework/protocol that implements statistical multiplexing at the application layer also focusing on synchronizing the haptic, audio and video streams [60].

The authors of [61], focusing on telesurgery, have presented an application layer protocol, called the Interoperable Telesurgical Protocol (ITP), but in the experiments performed the communication was not bilateral, the users only had visual feedback. It should be noted, though, that the protocol could be extended to be used in implementations with data transforms such as the wave-variable transform (discussed later in Section

V).

In physical teleoperation systems with constant bitrate communication channels, a multiplexing scheme has been proposed for transmitting video and haptic data with the application of perceptual data reduction using the ZOH method [31]. While multiplexing, if no force data are to be sent then the video data are prioritized. By assuming a constant bitrate connection, packet delay can be computed and used for correctly demultiplexing the data stream. Another framework that employs the *Just Noticeable Difference* (JND) method, explored later on in this paper, is the *Haptics over Internet Protocol* (HoIP). Implemented in C++, HoIP is using the unreliable UDP and a multiplexing algorithm that enables the packetization of either haptic and audio data or haptic and video data. The header of each packet allows the estimation of QoS parameters, the use of adaptive sampling by employing the JND method and also a flow control mechanism [62].

Furthermore, other frameworks that exist perform QoS management over overlay networks. In [63] methods for error correction and optimal path selection are applied for efficient data stream transmission. Finally, in [32], a module measures the complexity of a task to dynamically adjust the number of active paths and network resources for each media stream.

Last but not least, there are two application layer protocols with a focus on security which is a major concern for e.g. telesurgery applications. These are Secure ITP [64], a version of the previously mentioned ITP extended to be more secure and the Secure and Statistically Reliable UDP (SSR-UDP). The first one implements user authentication and authorization as well as data encryption using the Advanced Encryption Standard (AES). In the latter one, the system design includes transmitting data with what the authors call a "privacy scheme" as well as a feedback channel for sending acknowledgment packets back to the master device [65].

In Table II, there is a qualitative comparison of all aforementioned application layer protocols. Two of the listed protocols (ALPHAN and Admux) are used specifically for virtual environments, while three of them (PAHCP, HoIP and ALPHAN) implement data reduction. HoIP, Admux and ADAMS multiplex audio and video and haptic data but none of the protocols except Secure ITP and SSR-UDP incorporate security mechanisms.

TABLE II
COMPARISON OF APPLICATION LAYER PROTOCOLS

	Data Reduction	Mux (Audio-Video)	Security	Virtual Env. only
PAHCP [58]	✓	X	X	X
HoIP [62]	✓	✓	X	X
ALPHAN [59]	✓	X	X	✓
Admux [60]	X	✓	X	✓
ADAMS [53]	X	✓	X	X
ITP [61]	X	X	X	X
Secure ITP [64]	X	X	✓	X
SSR-UDP [65]	X	X	✓	X

B. Provision of QoS in the network

By itself, Internet operates on the best-effort basis by treating all packets in the same way, therefore not guaranteeing

QoS. Number of approaches have been proposed to provide QoS including: relative priority marking, service marking, label switching, static per-hop classification, *Integrated Services* (IntServ) and *Differentiated Services* (DiffServ). Each of these categories have been implemented in different ways, but because of relevance, we explain IntServ and DiffServ further here, while the latter being the most scalable and thus more preferred solution currently.

The IntServ architecture [66] relies on the storage of information in all routers of the network in terms of flows that will pass through them. A preallocation of resources is done using the relevant signaling protocol in order for the data stream to travel end-to-end. The downside of IntServ is mainly its scalability as supporting a large network such as the Internet can easily become too complex. Also, the periodic information update concerning each flow can increase the traffic significantly.

On the other hand, DiffServ is not providing QoS to separate flows. Instead, it classifies flows by labeling the data streams. DiffServ is implemented in IPv4 and IPv6 [67] as a field inside the IP header of a packet called Type of Service (ToS) and Traffic Class (TC) respectively which determines how the network should manage each packet in a per-hop behaviour (PHB). With a total amount of 64 different classes (6 bits of the octet) available, DiffServ allows the aggregation of different flows into a single class. It is important to mention that DiffServ is completely transparent to all Layer 2 mechanisms as it operates exclusively on Layer 3.

Two important mechanisms of DiffServ are the Expedited Forwarding PHB (EF PHB) and the Assured Forwarding PHB (AF PHB). The first one, is highly related to haptic communication as it provides queue prioritization for applications/services with high requirements in terms of packet loss, latency, jitter and data rate. On the other hand, AF PHB offers a framework for providing different drop rates which depend on a predefined table of drop rate classes.

Furthermore, using the aforementioned protocol features is not an easy task since monitoring and dynamic management of resources which requires the configuration (and re-configuration) of all network nodes is demanding. Hence, flexible traffic management while simultaneously supporting strict and dynamic QoS requirements is yet critical and challenging in the Internet. On the other hand, the effective and quick adaptation of resources to the actual traffic demand is one of the main features expected to be effectively handled by next generation networks, that will also be a key enabler for the Tactile Internet. A step forward in introducing flexibility in network management is represented by the Software-defined Networking (SDN), where control and data planes are decoupled and split into logically centralized network intelligence and an underlying abstracted infrastructure [68]. Among the various key features of SDN, the programmability and agility of the network (re)configurations can significantly ease management of diverse QoS requirements, while the logically centralized control enables scalability. Using features such as queues and meters per flow basis across the end-to-end path, for example, provides granular QoS and can allow for prioritization of more latency demanding flows such

as teleoperation flows that can be dynamically reconfigured depending on the volume of traffic [69], [70].

At this point we need to mention that flow prioritization and net neutrality are contradictory concepts but this discussion is out of the scope of this survey and will not be further discussed.

C. Network Security

Security is yet another cornerstone of the Tactile Internet, considering teleoperation sessions often represent critical communication scenarios. Security has indeed been subject of recent research under the umbrella of *cyber-physical systems* (CPSs) to address the needs of emerging sensor networks [71]. In [72], a list of threats and possible attacks on teleoperation systems are presented, along with a QoS-friendly IP security (IPsec) protocol suite. In addition, as mentioned in [73], nowadays security threats of CPSs are not focused on communication standards only. All layers of communication, from physical to application, can be targeted. Despite its importance, in this survey, we devote our attention to the enablers of reliable low-latency communications and hence security is not within context.

Nonetheless, it needs to be mentioned that methodologies for enhancing security of communication have a negative impact on the end-to-end latency. This is another trade-off to be taken into consideration when designing a haptic communication system. Therefore, it is a challenge to integrate security in such systems.

IV. HAPTIC DATA REDUCTION AND COMPRESSION

Haptic sensor readings, especially when reading the kinesthetic signals, as previously mentioned in Section II-C, have a sampling rate of 1 kHz or even higher. In order to keep the communication delay as small as possible, haptic samples are packetized and transmitted instantly. As a result, the communication of haptic data in teleoperation systems requires 1000 or more packets per second to be transmitted. For vibrotactile signals (touch emulated with vibrations), the sampling frequency greatly depends on the type of interaction of the user with the remote environment. For tasks of low precision, it requires a feedback frequency of 20 Hz to 30 Hz, while high precision tasks require a feedback frequency of 5 kHz to 10 kHz [74]–[76]. Such high rate of packet transmission incur substantial data overhead due to the transmission of packet header and, thus, results in increasing latency [77]–[79].

Future teleoperation systems which will be able to provide full body immersion will use a large number of sensors and actuators increasing proportionally to the number of Degrees-of-Freedom required by the haptic applications. Even though 5G networks will have data rate capabilities which can easily cover the needs of a haptic data transmission of a user, it is necessary to have in mind the additional transmission of audio and video data. Therefore, it is required to explore and improve haptic data reduction and compression methods.

Haptic data reduction techniques, either for kinesthetic data reduction or tactile data reduction, can be considered as lossy data reduction/compression schemes as full recovery of the

original raw data is not possible. These techniques can be applied in the Application Layer since they rely on processing the data as acquired by the haptic devices. On the other hand, network throughput reduction can be achieved by other means such as Physical Layer Network Coding (NC) which will be discussed in Section VI viewed from the scope of the 5G infrastructure. In this section, data reduction will be related to the processing of haptic data only.

A. Kinesthetic data reduction

Kinesthetic data reduction techniques are mainly based on two approaches of statistical and perceptual schemes [58]. The former one normally uses the statistics of the haptic signals to compress the packet size, while the latter one mainly focuses on reducing the packet rate over the communication network. Since the packet header overhead is significant as kinesthetic data packet payload size is small, reducing the frame rate seems to be an obvious choice for reducing the total amount of data.

1) Statistical schemes

Early attempts with respect to signal sampling employ predictive models to reduce data redundancy. Quantization techniques (e.g., Adaptive DPCM) for kinesthetic data reduction are presented in [80]. In [81], kinesthetic data are 32-bit IEEE floating-point values. After the master and slave device have exchanged enough raw data, a simple position prediction method was proposed. Compression was achieved by performing an exclusive-or operation between the predicted and the previously predicted value and the result being reduced to 8 important bits.

Apart from prediction, lossy kinesthetic data compression and decompression has also been achieved by using discrete cosine transform (DCT) [82], similarly to the JPEG codec, in a teleoperation system with force feedback with a compression ratio of 20%. Finally, another compression method that has been tested on 1-DoF haptic data is Wavelet Packet Transform (WPT) [83]. In this case, decompression is accomplished with the Inverse WPT (or IWPT).

2) Perceptual schemes

The first proposal that targets packet rate reduction for networked control systems can be found in [77]. In this work only samples that contain changes more than a given/fixed threshold are transmitted. The receiver reacts to a missing sample by holding the value of the most recently received sample. The approach in [77], however, ignores that the human operator comes with strong limitations in terms of perceivable signal changes.

State-of-the-art methods of perceptual data reduction have shown that, it is possible to exploit the limitations of human operators and how they perceive haptic signals [84] towards achieving more efficient data reduction [85]. Such works mainly rely on a concept from psychophysics that is the difference threshold, otherwise known as *Just Noticeable Difference* (JND), which is the minimum amount of change in stimulus intensity needed for a perceptible increment in

sensory experience. This threshold is formulated by Weber's law [86]:

$$\frac{\Delta I}{I} = c \quad (1)$$

where I is the stimulation intensity, ΔI is the difference of stimulation intensity to be perceived (the JND) and c is a constant, also known as the Weber's fraction. Difference thresholds, also known as discrimination thresholds, are defined both for haptic system parameters and quantities such as stiffness, velocity and force. These thresholds also differ depending on the movement scenario and the muscles involved [87]. For example, the JND when a human operator perceives force feedback to the index finger is approximately 10% [88]. Implementing kinesthetic data reduction showed up to 90% decrease in packet rate in [78]. Perceptual kinesthetic data reduction schemes have also been implemented for position and velocity signals using distance metrics (the Euclidean distance) between haptic data vectors (position vectors) [89]. This approach, however, needs further investigation because in psychophysics there is no result that shows Weber's law also applies to positions. This methodology also applies to orientation data and has also been extended to six degrees of freedom (DoF).

In comparison to other sampling methods such as the level crossings method (that incorporates absolute differences instead of percentages between samples), the perceptual-based kinesthetic data reduction schemes are proven to have good but similar accuracy [90]. Nonetheless, in [91] it is stated that the *level crossings sampler* outperforms the sampling method based on Weber's law. It has also been shown that the JND decreases with increase of the rate of kinesthetic force stimuli.

3) Perceptual schemes with predictive coding

Prediction models of haptic signals can be used to estimate future haptic samples from previous data. This is able to achieve further reduction of haptic packet rate. As illustrated in Figure 4, the same predictors can run in parallel at both the master and slave sides. At the sender side, the predictor generates the predicted haptic signal at every sample instant. If the prediction error is smaller than the corresponding JND, no update is triggered. Otherwise, the input sample is transmitted to the other side and the transmitted sample is used for updating the prediction model. At the receiver side, if a packet is received, it is directly applied as the output and the received haptic signal is used for updating the prediction model. Otherwise, the predictor generates a predicted haptic signal as the current output.

The simplest but also the least efficient prediction method is the zero-order hold (ZOH) predictor. When no data have been transmitted from the sender the receiver holds the last value of the sample it previously received.

Different kinds of predictors can be used to estimate the future haptic samples. For example in [79], [92], a linear predictor of the first order was adopted, namely a first-order linear predictor (FOLP). This simple predictor can lead to a significantly decreased packet rate up to 90-95% without deteriorating the immersiveness of the system. The velocity signal approximation used in the prediction model, however,

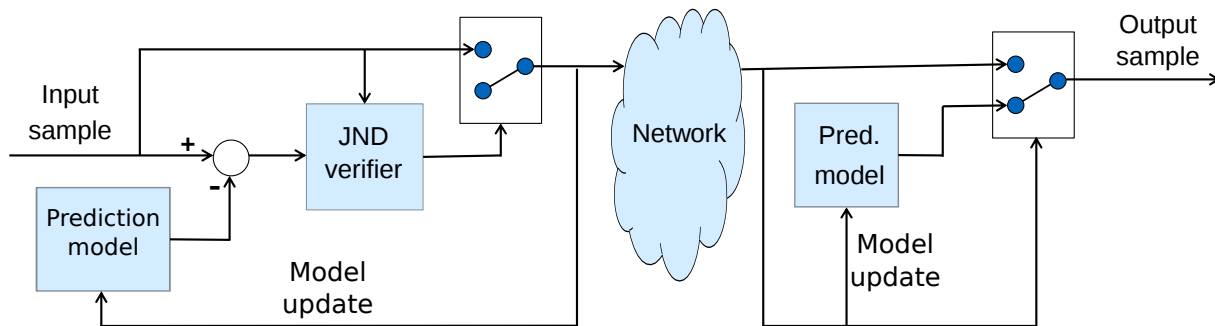

Figure 4. Overview of the perceptual kinesthetic data reduction with predictive coding

is very sensitive to noise, even more than force signals. Therefore, haptic samples need to be filtered by using a low-pass filter to minimize the undesirable effects of measurement noise. An augmented version of this framework, presented in [93], introduces noise reduction by employing a scalar Kalman filter on the input signals.

Yet another prediction model that takes the prediction error into account was employed in [94] for three-dimensional position and force data, a third-order autoregressive (AR) model. According to the method's algorithm, after an initialization and training process, the adaptive coefficients of the model are computed so that the predicted values are produced. Afterwards, taking into account the JND threshold, the algorithm decides whether the training values need to be updated either from the predicted data or the current real data.

Contrary to transmitting sample values obtained from haptic devices or their derivatives, regression analysis also allows the transmission of only the model parameters. Such a method can be found in [95] where samples are first fitted in a quadratic curve.

Using a more complex predictor, a geometry-based prediction model was proposed in [96]. The remote environment is modeled either as a plane or a sphere according to the historical interaction, without taking friction, slave inertia and time delay of the network into account. The future haptic samples were predicted based on the interaction with the geometry model. Taking into account a total of four predictors (ZOH, FOLP, plane and sphere predictors), a predictor selection method is also proposed in [96] which identifies the predictor with the least prediction error. Psychophysical tests on human subjects showed that the hybrid approach performed as well as the best predictor (sphere predictor).

Prediction of signal samples and perceptual coding of the signal was also proposed in [97] by implementing the Particle Filtering method. This framework uses the probability distribution function (PDF) of the user's motion or force to predict future or lost samples.

B. Tactile data reduction

While data reduction on kinesthetic signals is widely investigated as discussed in the previous subsections, the number of studies on the compression of vibrotactile texture signals is

limited. The kinesthetic signals involve large amplitude low-frequency force feedback and were found lacking in realism due to the absence of high-frequency transients (e.g., tapping on hard surfaces [98]) and small-scale surface details (e.g., palpation of textured surfaces [99]). Transmission of vibrotactile signals for increasing fidelity of real-time teleoperation systems and its storage for later playback necessitate data compression.

The necessary step before compressing the vibrotactile signals is to model them. Significant research has been devoted toward modeling tactile texture signals [100]–[102]. The vibrotactile signals are raised from coarse regularly patterned textures by decaying sinusoids [100]. In [101], Kuchenbecker et al. use a linear predictor to model the texture signals. In [102], the authors segment the recorded real-world vibrotactile texture signals based on their physical surface feature. These segmented signals are fitted and the corresponding filter parameters are stored. Then, a virtual visual-haptic model representing the previously extracted surface features is constructed and haptic rendering is performed based on this model. The above works, however, are not optimized for compression.

Towards the compression of vibrotactile signals, Okamoto and Yamada presented a frequency-domain texture compression algorithm loosely based on the knowledge of human vibrotactile perception [103]. The textured surfaces are scanned and the surface height is represented by a waveform. This waveform is transformed to the temporal frequency domain using the Discrete Cosine Transform (DCT), and the DCT coefficients are thresholded and quantized according to the knowledge of frequency-domain amplitude-Just Noticeable Differences (JND) for vibrotactile stimuli [104]. The authors of [103] showed a 75% compression of the texture data with guaranteed perceptual transparency. Unfortunately, this algorithm works only offline, which means prior knowledge about the surface must be known (e.g., pre-scanning procedure). Further research on JNDs of vibrotactile perception has been made in [105] by studying the JNDs with low-intensity reference stimuli, starting at 5 Hz, close to the sensory absolute threshold. In [106] three experiments were carried out, first an experiment showing that acceleration is not a vibration property that affects humans due to the nature of the human tissue, second an experiment to determine JNDs showing it is unimportant to subjectively optimize tactile displays and

third an experiment that showed the impact of using different devices in low frequency vibrations (starting at 100 Hz).

The first online compression of vibrotactile signals can be found in [107] for bilateral teleoperation. The compression algorithm is inspired by the similarities observed between texture signals and speech signals. Thus, a well-developed speech coding technique, the Algebraic Code-Excited Linear Prediction coding (ACE-LPC) [108], is adapted for developing a perceptually transparent texture codec. The authors of [107] reported a compression rate of 8:1 with a very low bitrate (4 kbps) on data transmission. An extended version of this compress algorithm was proposed in [109], in which the masking phenomenon in the perception of wide-band vibrotactile signals was applied to further improve the efficiency of the texture codec. The masking phenomenon [110] implies that humans can tolerate larger errors in high-energy frequency bands, and smaller ones in low-energy frequency bands. Therefore, for encoding (compressing) the texture signals, the bitrate should be allocated more in the low-energy frequency bands compared than to the high-energy ones. In [109], the authors experimentally showed that the masking for haptics is very similar to its auditory analog. With the help of the experimental results, the bitrate of the codec output can be driven down to as low as 2.3 kbps without distorting the subjective perception.

Last but not least, it must be noted that there is currently no objective quality metric, such as *Mean Opinion Score* (MOS), for the evaluation of vibrotactile signals (with the exception of [111] on the effect of delayed kinesthetic and 3D video data on the user). Nonetheless, the similarities shared between audio and tactile signals will allow the design of tactile codecs in a similar fashion as with audio codecs [112].

V. HAPTIC CONTROL SYSTEM APPROACHES

As the network infrastructure and mechanisms keep improving there are physical barriers, as in the case of long distance communications, that can introduce a minimum latency which can make certain teleoperation applications impossible. As previously mentioned, latency can disrupt the stability of a bilateral teleoperation system. Although this is true, there are stability control architectures and methods that can minimize the impact of latency. Therefore TPTA systems will not solely rely on 5G network infrastructure for optimizing the QoS of the communication channel to the standards of each application, but will be able to compensate for delay to a certain extent.

The foundation of teleoperation system control analysis is a model that best characterizes the interaction between the human and the remote environment. This model is usually in the form of a mass-spring-damper system which portrays the behaviour of the master and slave subsystems. A common way to describe this behaviour is the Euler-Lagrange equations of motion for the joint-space nonlinear dynamic model of an m-DoF master and slave device [113].

In this section we will focus on robust stability control methods and concepts that offer the possibility of jointly using data reduction along with their background (subsections

V-A-V-F, V-I). We also mention methods for closed loop teleoperation implementations that model time delay, system plants and the robot devices in order to compensate for any delays (subsection V-G). Furthermore, we mention other control methods for the sake of completeness (subsection V-H).

A. Control architectures

The different control architectures that permit signals to be exchanged between a human operator and the remote environment can be classified according to the arrangement of the control system building blocks. In order for the system to meet the objectives for teleoperation of acceptable quality, adaptive control subsystems can be introduced in the teleoperation system design. This results in a wide range of different mechanisms and architectures that attempt to tackle the issues of telemanipulation [114]. A comparison of different control schemes was presented in [115] stating that all schemes have advantages and disadvantages and that it is in the discretion of the system designer to choose which is the best one for his application.

Bilateral control teleoperation system classification can be based on whether the system targets to compensate for communication delay, focuses on estimating the operator and environment model, is responsible for handling internal and external disturbances of the subsystems, or, provides a combination of the aforementioned tasks. Another approach for classifying teleoperation systems states that the information processed in the system for controller gain adaptation is focused on the *environment*, the *human operator* or the *task* to be accomplished, therefore calls these controllers EOT-adapted controllers [116].

The two most common generic control architectures, based on the number of communication channels the system uses, are the two-channel (2CH) and the four-channel (4CH) architectures. In the former one, the master and slave manipulators need to establish only one channel for each direction of the bilateral communication, whereas in the latter one, both velocity and force information is exchanged by using two different channels for each direction. There are also other possible schemes with one human operator and multiple slave devices [117] or multiple human operators and multiple slave devices [118]. A human operator may also communicate with a virtual environment, instead of a haptic device, where computational delay must also be taken into account (no delay, constant and time-varying delay) [119], [120].

It must be mentioned that there are numerous control schemes which could be mentioned in this section. However, the aim of this paper is not to summarize all existing control schemes, but to survey the work that jointly addresses the stability and communication challenges for networked teleoperation systems. Currently, only the control schemes which will follow, namely the Wave Variable control, the Time-Domain Passivity Approach and the Model-Mediated Teleoperation Approach) are combined with data reduction methods. Therefore, we focus on these three control schemes. Combining other control schemes with data reduction approaches is an interesting work for future investigation.

B. Transparency and stability

Transparency and stability are key aspects of a haptic teleoperation system and also the main focus of system control techniques. A fully transparent system is a system in which telepresence is a flawless and seamless experience. To achieve transparency, the system also needs to be stable for an expected (bounded) behaviour of the operator and the remote environment. In practice, there is a conflict between transparency and stability and a compromise needs to be made [6].

A stable system must always have bounded output for a bounded input. Bounded signals are those which do not exceed a finite value over time. Transparency of a bilateral control system can be defined in many ways, the most popular being the mechanical impedance approach. In this approach, maximum transparency is achieved when the impedance the operator is the same as the impedance of the environment [121], known as impedance matching.

Based on linear time-invariant (LTI) dynamics in the Laplace domain, maximum transparency is achieved when the human and environment impedances are matched. The human impedance is defined by the ratio of force applied by the teleoperator to the velocity of the master device, and the environment impedance is the ratio of the force slave device receives from the environment to the velocity of the slave device.

In [122] the notions of reproducibility and operability, which complement stability, are investigated as two goals that when achieved the condition for transparency is satisfied. Reproducibility is referring to the reproduction of the environmental impedance from the master manipulator, whereas to achieve ideal operability the operational force (additional undesirable force produced by the system controllers due to inaccuracies) should not be felt by the human operator and therefore must be zero.

Furthermore, theoretically, any non-zero value of delay leads to instability. However, the damping of the haptic device, slave dynamics and human arm movement contribute to the stabilization of the system. As a result, there is some tolerance, which varies for different system settings and teleoperation tasks [123].

C. Passivity-based control

Built upon the idea that bilateral control systems must be passive and therefore stable by Anderson and Spong [124], passivity-based control methods have been applied to haptic communication systems in order to compensate for time delays or data loss. Due to its effectiveness in non-linear control systems it has been thoroughly studied in teleoperation systems.

Nonetheless, the passivity condition applies only if all the system components are or are assumed to be passive (i.e. subsystems that do not produce energy), as any arrangement of passive components results in a passive system. With regard to teleoperation systems, the previous statement also applies to teleoperation systems assuming that the human operator and the remote environment behave as passive elements along with the existence of an ideal communication channel. Concerning the human operator, this assumption is only valid for the sake

of simplicity, otherwise it does not hold for all kinds of tasks as stated in [125].

In general, a teleoperation system can be modeled in various ways, such as the two-port network model [126], [127] or the port-Hamiltonian system approach [128]. Focusing on the two-port network model, all subsystems between the human operator and the environment can be represented by a two-port network where energy flows through its inputs and outputs. From an electrical domain point-of-view this can also be viewed as a transmission line system that ideally is needed to be lossless (with perfect impedance matching). In this domain, force is represented as voltage, position as current and therefore the product of the two is power. A two-port element inside a teleoperation system can be characterized as passive when the energy (integral of power over time) of the output of the two-port element is greater than the energy of the input [129].

An alternative analysis in [130] investigates bilateral control system stability with a non-passive human operator or teleoperation environment using Mobius transformations.

Since the communication network of a TPTA framework introduces delays, which can be represented in a control architecture by active elements, it is where passivity-based control needs to be applied. A detailed description of the theoretical base of passivity-based control has been made in [131]. Wave-variable (WV) control and time-domain passivity control (TDPC) are such methods and will be discussed in the next subsections. Furthermore, augmented versions of these methods have also been proposed.

Passivity-based approaches have been proposed both for linear and non-linear teleoperation systems [132]. Alternative teleoperation control methods to the passivity-based approach are proportional derivative (PD) or PD-like control [133], PD control for stochastic stabilization [134], for adaptive time-delay compensation [135] or without, \mathcal{H}_∞ -control and μ -synthesis [136], [137], the computationally complex but constantly improved Model Predictive Control (MPC)[138] methods, fuzzy logic system approaches [139], [140] or the more recently proposed immersion and invariance (I&I) observer methods [141]. Passivity-based control methods can be applied on each DoF of a teleoperation system, but, the system becomes more conservative [142].

Acceleration-based bilateral control methods have also been proved to provide robust stability even when the system is under time delay both for two-channel [143] and four-channel architectures [144], [145].

Network delay, especially when it is considered as time-varying, becomes a hindrance for the synchronization of master and slave positioning and the transmission of the human operator's movement trajectory or the remote environment's force feedback. For each teleoperation framework, several augmented versions that attempt to optimally solve the position tracking issue have been proposed such as the sliding-mode controller architecture [146].

Using the representation of the two-port network model for teleoperation in the frequency domain and Llewellyn's absolute stability criterion [147], it is possible to define the scattering approach which examines how scattered waves

(output of the communication network) differ to their original form (input of the communication network) [127].

By creating abstraction layers for transparency and passivity, a haptic system that transmits mixed feedback of kinesthetic and tactile information was described in [148], also providing additional tactile force feedback when the passivity layer disrupts the kinesthetic force feedback in order to preserve passivity.

D. Wave-variable control methods

The previously mentioned work of Anderson and Spong which combined scattering transformation, network theory and passivity control, led to the concept of wave-variables (i.e. wave-variable transformation) by Niemeyer and Slotine [149], [150], used in haptic communication systems by algorithms created to ensure stability and transparency between the master and slave device when time delay is introduced [151]. Viewing the system from a virtual transmission line point-of-view the wave-variables represent the incident and reflected waves respectively and the wave (or virtual) impedance can be used to control the behaviour of the system to preserve passivity.

A quantitative comparison of the performance between the two-channel and the four-channel wave-based control schemes revealed that the four channels of the 4CH architecture can be reduced to three and also achieve better performance than the 2CH architecture. Even so, the 2CH scheme is able to achieve similar performance with better stability robustness, while being less complex to implement [152]. Wave-based bilateral control has also been applied to micro-teleoperation systems in which the slave device operates on soft/fragile objects [153]. Furthermore, wave variables can also be used in multiple-DoF teleoperation systems by adopting more general equations that incorporate impedance matrices, also called scaling matrices [154]. The scattering transformation also allows the power transmitted from one side of the teleoperation system to the other to be scaled, a characteristic of a passive two-port system.

With the adoption of the scattering transformation, converting power variables to wave variables raises important issues. On one hand, power variables preserve passivity, on the other hand, they also introduce desynchronization and the phenomenon of wave reflection which disrupts the system transparency. The position tracking error, also known as position drift, and the force tracking error between master and slave is caused because of the time delay introduced by the system's communication channel and the fact that it is impossible to perfectly model the environment in which the slave device is operating. To resolve this issue, several attempts have been made either for constant time delay [155] or varied time delay [156] in the communication channel. An augmented version of the wave-based control architecture is recommended in [157]. Other methods propose several techniques and schemes such as the transmission of wave integrals [158] along with wave energy [150], predictors [159] to compensate for network delays or even communication blackouts [160] or the utilization of neural network theory for enabling improved modeling of the system which is considered

as nonlinear [161]. In [162], Munir and Book proposed a method that corrects the position tracking error taking time-varying delay into account. This method employs a modified Smith predictor, a Kalman filter and an energy regulator. An improved version of this method was suggested in [163]. Several alternatives have been proposed as well in the scope of wave-variable control [164]–[167].

E. Time-domain passivity control

The time-domain passivity approach (TDPA) was defined by Hannaford and Ryu [168] for haptic interfaces and extended to apply to teleoperation systems [169]. The approach has gained interest during the past few years due to its simplicity and robustness to communication delays.

The basic concept behind time-domain passivity control is to monitor the energy flowing to and from the master, the slave side or both in real time using a *passivity observer* (PO) which can be placed in series or in parallel to the communication channel. In the series arrangement we choose velocity as an input, whereas in the parallel arrangement force is used as input to the PO. If the PO decides that the passivity condition is not satisfied, meaning that the system generates energy and therefore is active, then, a *passivity controller* (PC) has the responsibility to retain the system's passivity by using adjustable damping elements [170]. Besides being applied to 1-DoF applications, TDPA has also been applied to 6-DoF systems [171].

Following a relevant arrangement in [172], after the acquisition of the environment parameters (related to velocity and force data of the slave device) and transmission through the communication channel, a model of the environment is created on the master side and according to this model the damping coefficients of a PC are adjusted according to a PO's output.

Bounding energy signals [173] or control signals [174] of TDPA systems has showed improvement of the method's effectiveness. In [175], a different scheme, as in Figure 5, is proposed where the segment of the control system on the teleoperator side including the communication block is considered as a one-port network that receives position and provides force feedback. A method that combines time domain passivity control with perceptual data reduction is introduced in [176].

An augmented version of TDPA was proposed in [178] based on the framework of network-based analysis of passivity-based teleoperation systems in [179]. Modeling the teleoperation system using an electrical representation, rather than a mechanical one, is beneficial due to its simplicity. The electrical representation employs ideal flow (velocity) and effort (force) dependent sources as the analogous system elements to the motion commands of the human operator and reflected force of the teleoperator. These sources can also be delayed dependent.

The communication channel equivalent is called *Time Delay Power Network* (TDPN) and it is in the form of a two-port subsystem that can be coupled with a passivity controller. Another differentiation of this framework lies in the possible structures of the proposed architecture as it further disam-

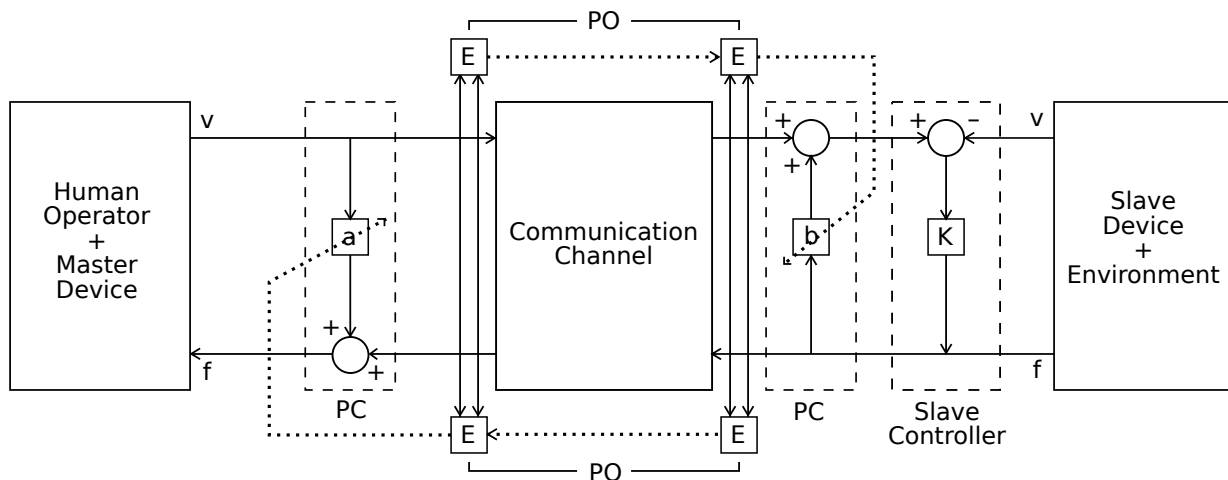

Figure 5. A bilateral teleoperation system using the time-domain passivity control architecture (from [177]). The Passivity Observer (PO) entities compute the energy flows for both directions and provide input to the Passivity Controller (PC) on each side.

biguates the network channel representation, with regard to the energy flows.

Furthermore, TDPN modelling can be also applied to four-channel architecture systems [177]. In another approach, a system segmented in such a way as to provide three types of force feedback is presented in [180]. Further improvement of the TDPN method has been proposed in [181] with respect to position drift and by suggesting a different feedback scheme where the measured force from the environment is directly sent to the master.

F. Model-mediated teleoperation approach

As previously discussed, stability and transparency are conflicting objectives in passivity-based teleoperation design. This means that the system gains stability at the cost of degraded transparency. For example, the perceived stiffness of the remote objects decreases with the increase of communication delay [182].

To guarantee both the system stability and transparency at the same time in the presence of arbitrary communication delay, the concept of the *Model-Mediated Teleoperation Approach* (MMTA) has been proposed. The main concept is illustrated in Figure 6 where it is shown that rather than directly sending back the haptic (force) signals, the parameters of the object model which approximate the remote environment are estimated and transmitted back to the master in real time during the slaves interaction with the remote environment. The model parameters include the surface geometry and physical properties of the remote objects. On the master side, a copy of this object model is maintained according to the received model parameters, and the haptic feedback is computed on the basis of the local model without any delay. The MMTA was first presented in [127] and afterwards extended in [183].

The MMTA opens the control loop between the master and slave and leads to two decoupled control loops, one on the master and one on the slave side. The stability of the MMTA system can be determined using the stability of the human-master local model closed loop and the slave-environment

closed loop [116], [184]. If the estimated model is an accurate approximation of the remote environment, then both stable and transparent teleoperation can be achieved.

More specifically, in [127], the local control loops at one side of the haptic communication system aim to simulate the impedance observed at the opposite side. Later on, in [183], in contrast to transmitting position or force values, an abstraction layer was introduced, but implemented for a 1-DoF application. The suggested algorithm replicates the remote environment at the master side and issues commands through the communication channel to the slave device.

When the master receives new model parameters from the slave side, an update of the local model according to the received model parameters is required. Ideally, the parameters of the local model need to be updated to the correct ones as quickly as possible. However, improper update schemes, e.g., a sudden change in stiffness or model position, result in a suddenly changed force that is displayed to the human user. This is called the model-jump effect [185]. To allow for a moderate model update which guarantees the stability, passivity-based schemes were developed [183], [185], [186]. In [183], [185], the model position is updated only if no energy is injected into the local model system after the update. In [186], the authors used an adaptive damper to dissipate the energy injected into the local model system during the model update. This allows for a quicker model update and a higher subjective preference rate compared to the scheme proposed in [183], [185].

In general, MMTA has the benefit of being simultaneously stable and transparent in 1D or simple 3D real environments compared to the passivity-based control approaches. However, due to the limitations of existing online model-estimation algorithms, the MMTA cannot work efficiently in complex or completely unknown environments.

There is no doubt that obtaining a precise object model for complex environments (both object geometry and physical properties) is the most important task and also the main challenge for the MMTA, since a perfect match between the local

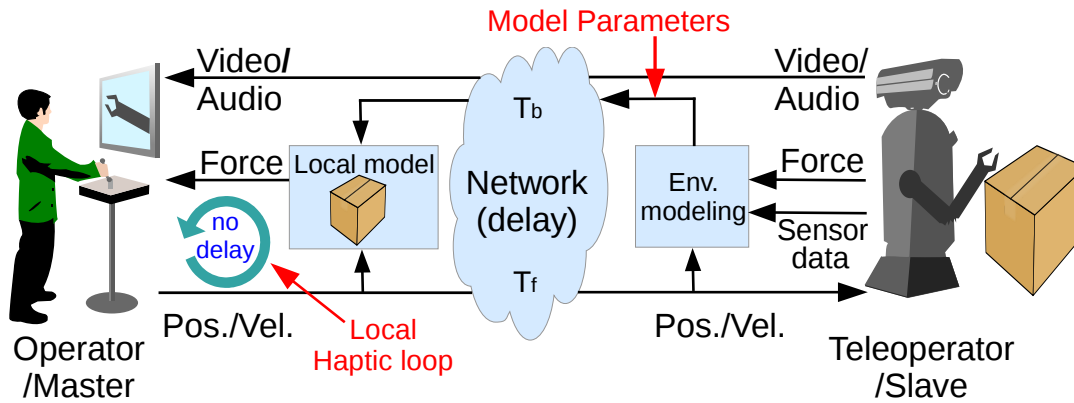

Figure 6. Model-mediated teleoperation approach (MMTA). The user interacts with the remote environment indirectly, i.e. using a model which receives model parameters from the slave device. At the same time the user’s movement data are transferred through the network to the slave device.[183]

model and the environment enables stable and transparent teleoperation in the presence of arbitrary communication delays. Early attempts employ predefined model for MMTA systems [126]. This requires the master system to have rich knowledge about the remote environment. In practice, there are situations in which we have limited knowledge about the remote environment, especially when the slave enters a new environment or interacts with dynamic (movable or deformable) objects. Therefore, online environment modeling and model updating are inevitable. In recent decades, online environment modeling (parameter identification) for teleoperation systems has been widely investigated, e.g., for estimating linear [187], [188] / non-linear [189], [190] environment models, rigid [96] / deformable [191] / movable [192] objects, and for estimating unknown environment models using online neural network approaches [193], [194].

Instead of modeling the environment, an alternative architecture of the MMTA is to model the behavior of the human operator. The estimated model parameters on the master side are transmitted to the slave to guide the slaves motion. The slave is thus not controlled by the delayed master motion commands, but performs specific tasks in complete autonomy based on the received human behavior model. Similarly, if the model as well as the model parameters can accurately approximate the human behavior, the slave can behave like a human user and a complete skill transfer can be realized [195]–[197]. The modeling of human behavior, however, is quite challenging and the model of human behavior has not been fully studied yet. Most of the MMTA are thus based on the modeling of remote environments, but not the modeling of human behavior.

The estimated model parameters need to be transmitted back to the master for building/updating the local model. The transmission happens normally when the slave enters a new environment, the environment the slave is interacting with changes, or the parameter estimation is not precise. Once the estimates converge to the true values, there will be no updates required and thus the system achieves zero transmission in the backward communication channel. For real teleoperation systems, however, the estimates can vary over time due to

measurement noise, natural tremble of human arm movement, etc. Obviously, to transmit every estimate is a waste of the network resources. Thus, an efficient data reduction scheme is needed to selectively transmit the estimated model parameters. Verscheure et al. [198] presented an event-triggered estimation scheme. The estimation and transmission are activated only when special conditions are satisfied, e.g. sufficiently large force/velocity of the slave, or sufficiently large displacement from the last estimation.

An alternative approach has been followed by other methods proposing a perceptual MMTA scheme where a prediction model is employed at the master and the slave side resulting in local closed-loop control on each side to ensure high fidelity. The models on both sides are updated in order to be in sync if the predicted values exceed the JND threshold. This combination of perceptual and statistical methods has been made in [199] by first applying the JND threshold and then a double exponential smoothing prediction algorithm to fill in the values not transmitted due to the threshold. Xu et al. [200] also applied the perceptual deadband approach to the estimated model parameters to reduce the transmission rate. The proposed framework incorporates 3D sensors to produce a point cloud model of a static rigid object’s surface in the remote environment. The depth images are processed with a median filter and then with a temporal averaging filter to reduce noise and fill holes in the depth image. Afterwards, the depth image vectors, which consist of a 2D position and the corresponding depth value, are transformed from pixel coordinates to real world coordinates. This enables the object’s geometry modeling while the slave device is in free space (not touching the object). Physical properties of the object (friction coefficient and stiffness) are also computed. Extrapolation is used when the slave device needs to operate outside the area produced by the point-cloud model, although issues are very likely to emerge. The authors of [200] also reported a data reduction of about 90% with guaranteed (significantly high) subjective quality of teleoperation. Augmented feedback information was also considered in [201] again with the use of a stereo camera.

G. Smith Predictor and Communication Disturbance Observers

In the previous section, MMTA is using the environment model to compensate for the delays allowing the user to interact only with the estimated model of the remote environment. Another well known but closed loop control scheme, the Smith predictor, is using a plant model transfer function and a time delay model to compensate for the network delays in the communication. This has been extended with the addition of neural networks to better deal with the nonlinear nature of the remote environment [194].

The concepts of network disturbance (ND) and communication disturbance observer (CDOB) have been proposed in order to compensate for time delays. This approach uses the transfer function model of the robots, in order to estimate the communication disturbance [202]. The influence of the controller parameters on a CDOB system's transparency is analyzed in [203]. This method has been extended in order to work with variable delay in [144].

Augmented versions of the CDOB can also be used for the four-channel architecture [204]. Since works based on CDOB mostly focus on position control rather than force control, in [205], the authors propose a method for compensating in the presence of network disturbance in the force feedback channel. A comparison of different CDOB implementation has been shown in [206] along with a CDOB control scheme that integrates fuzzy control theory and neural network network modelling.

H. Other control schemes

The previously mentioned control schemes are passivity-based approaches for solving the instability caused by delays in the transmission of information between master and slave. In this subsection, we will refer to other bilateral teleoperation control schemes which are not based on the passivity of the system.

Recently, Jafari et al. [207] have proposed an input-to-state stable (ISS) approach to guarantee the stability of teleoperation systems. It allows a bigger output energy and is less conservative compared to the passivity-based control schemes.

The ISS approach is able to generate a bounded amount of energy in the teleoperation systems while still guaranteeing stability. It has also been extended for bilateral haptic teleoperation systems in the presence of communication delays [208]. Although the ISS approach is not fully developed compared to the passivity-based approaches, it shows great potential to improve the transparency due to its less conservative design.

In [209] there is a recent review of several predictive control methods with comparison and shows that a control scheme can be chosen over others for certain conditions and tasks.

I. Joint control scheme and data reduction

The aforementioned data reduction approaches for teleoperation systems in Section IV have been initially developed without considering the stability issues and control scheme. In the presence of communication delays, however, the data

compression schemes have to be combined with stability-ensuring control schemes. In this subsection, we briefly review the research works that studied haptic data reduction in combination with control schemes. Table III gives an overview of the efforts in the combination of control schemes and haptic data reduction approaches.

TABLE III
OVERVIEW OF THE COMBINATION OF TELEOPERATION CONTROL ARCHITECTURES WITH DATA REDUCTION SCHEMES FOR DIFFERENT COMMUNICATION ASSUMPTIONS.

	known const. delay	unknown const. delay	time-varying delay
WV + data reduction	[210]	[211]	-
TDPA + data reduction	[176]	[176]	[176]
MMTA + data reduction	[198], [200]	[198], [200]	-

1) Haptic data reduction + wave-variable control architecture

The perceptual deadband (PD) packet rate reduction scheme has been combined with the WV control scheme in [210], [211] for dealing with constant communication delay. The PD approach is applied either on the wave variables [211] or on the time domain signals [210] (force and velocity). In order to modify the control schemes and to incorporate data reduction schemes, the passive PD schemes, such as the energy supervising transmission [211] and the passive ZOH reconstruction scheme [210] were developed. In [211], the authors experimentally found the subjectively best deadband parameter for interacting with a rigid wall. In contrast in [210], the authors showed that applying the PD approach on time-domain signals leads to better performance on both system transparency and data reduction compared to applying the PD approach on wave variables.

2) Haptic data reduction + TDPA

Xu et al. [176] have recently combined the PD approach with the TDPA control scheme to reduce the packet rate over the communication network while preserving system stability in the presence of time-varying and unknown delays. On both master and slave sides the signals are processed with the deadband method to regulate the transmission rate of the velocity, force, and energy signals based on the PD approach discussed previously. In order to incorporate the control scheme with the PD approach, the energy calculation in the passivity observer (PO) is modified. At each sampling instant, if no update is received, the PO outputs the same energy as the most recently received one (ZOH reconstruction) for the subsequent computation.

Compared to the existing WV-based haptic data reduction approaches, the TDPA-based haptic data reduction scheme presented in [176] can robustly deal with time-varying delays and does not require the use of the passive PD approach. This is because the deadband controllers and reconstructors are set in between the two POs, and the TDPA is capable of ensuring passivity of any two-port networks between the POs on the master and slave side. Experiments show that the TDPA-based haptic data reduction scheme is subjectively more transparent compared to the WV-based schemes. In

addition, it is able to reduce the packet rate by up to 80%, without significantly distorting user's experience for the tested communication delays of up to $100 \text{ ms} \pm 30 \text{ ms}$.

3) Haptic data reduction + MMTA

Similarly, a perception-based model update scheme is also incorporated into a MMTA architecture [200]. The environment model as well as its physical properties (stiffness and surface friction coefficient) are estimated at the slave side in real-time and transmitted back to the master for building/updating the local model. The transmission happens normally when the slave enters a new environment, the environment the slave is interacting with changes, or the parameter estimation is not precise. Once the estimates converge to the true values, no updates are required and thus the system achieves zero transmission in the backward communication channel.

For real teleoperation systems, however, the estimates can vary over time due to measurement noise, natural tremble of human arm movement, etc. Obviously, to transmit every estimate is a waste of the network resources. Thus, an efficient data reduction scheme is needed to selectively transmit the estimated model parameters. Verscheure et al. [198] presented a event-triggered estimation scheme. The estimation and transmission are activated only when special conditions are satisfied, e.g. sufficiently large force/velocity of the slave, or sufficiently large displacement from the last estimation. Xu et al. [200] applied the perceptual deadband approach to the estimated model parameters to reduce the transmission rate. The authors also reported a data reduction of about 90% with guaranteed subjective quality of teleoperation.

The aforementioned perceptual or event-trigger control schemes for the MMTA avoid the transmission of irrelevant updates to reduce the packet rate on the network. System stability and transparency are verified in the presence of a round-trip communication delay of up to 1000 ms.

VI. HAPTIC COMMUNICATION OVER 5G MOBILE NETWORKS

Providing the services mentioned above in remote geographical areas and in an on-demand manner, where high bandwidth and dedicated networking infrastructure is not available, is yet another crucial aspect, which can be addressed by mobile networks. Furthermore, in comparison to fixed broadband networks, mobile networks have the advantage of having the ability to be deployed e.g. in case of emergency, a lot more rapidly.

Such scenarios become technically feasible due to progress anticipated with the 5G technology. Nonetheless, 5G will provide more than that. The transition from 4G to 5G is based on Key Performance Indicators (KPIs), such as latency, peak data rate (per user) and reliability among others, which define the challenges and targets towards 5G and that need to be improved in order for e.g. haptic communication to be realized.

Standardisation of the next generation 5G wireless communication systems has recently been initiated. Within the on-going 3GPP RAN 5G study item, also known as *New Radio*, technical components are being identified for a 5G radio interface and the next generation network architecture.

3GPP agreed to develop the 5G system specification in two phases, which correspond to 3GPP releases 15 and 16; a full system specification needs to be finalised and submitted to ITU by end of 2019. On-going work in both ITU and 3GPP define, at a high level, use case categories, resulting in requirements and evaluation methodologies for 5G system design. While earlier generations of mobile networks focused on mobile broadband services (targeting services for people), it has already been identified that 5G should, in addition, address the two new areas of massive machine-type communication (M-MTC) and critical machine-type communication (C-MTC), where services are provided to things and objects. Critical-MTC is, in 3GPP parlance, also referred to as ultra-reliable and low latency communication (URLLC). These two latter areas address the successive transformation of our society into a networked society.

According to [212] and based on data provided by the UK Office of Communications (Ofcom), the average RTT for 3G is 63.5 ms and in 4G it is reduced to 53.1 ms. RTT in this case is considered the time between sending a packet of data to a server and receiving a response. In the US, according to [213], presented in 2012, median RTT for 4G is 69.5 ms by measuring in a similar fashion the time difference between a SYN and SYN-ACK packet. As mentioned in previous sections these latency values are unacceptable within the scope of bilateral teleoperation with high QoE, as even with the application of stability control methods there will be a decrease of transparency.

A. 5G use cases and requirements

It is obvious that the 5G network capabilities are determined by the requirements of the use cases which will need to utilize effectively the network. Essentially, we need to iterate through the use cases and extract those requirements. This is something that has already been done by 3GPP mainly in [214] with further information in [215]. In Table IV we enlist the use cases using the first classification used in [214] along with a number of examples and briefly showing the main KPIs and requirements that need to be satisfied for the users to have good QoE.

Teleoperation is mainly related to the first three use case categories, but since a broad spectrum of applications exists, the different requirements can be grouped into many different classes. As seen in Table IV, the names of the use case families are self-descriptive as they include some of the main KPIs mentioned or a combination of them. These KPIs were selected to better demonstrate main the similarities and differences among the use cases. These include:

- *End-to-end latency* (e2e latency): The time it takes for data to be transferred from source device to destination (in milliseconds).
- *Reliability*: The number of packets successfully received by one end node divided by the total number of packets sent (percentage).
- *Availability*: The amount of time the communication system can provide service to the user divided by the total amount of time which is expect to deliver the services.

- *Mobility*: The speed at which the user is requesting services from the network provider. One example is telesurgery with the patient inside an ambulance moving with high speed.
- *Data rate*: The amount of data that the network can deliver in one second.
- *Coverage*: The area in which a network provider can offer services.
- *Positioning accuracy*: The accuracy at which a user's location can be tracked.
- *Security*: Maintaining the integrity of the data, in many cases, is a basic requirement. In Table IV, we also mention the relevant concept of confidentiality, which also relies on the network operator's discretion.
- *Service continuity*: Even when there is a change in the way a service is delivered to the user, this needs to happen in a seamless manner. This change can be a different access technology (e.g. satellite).
- *Energy efficiency*: The amount of bits per Joule of energy consumed.

We need to mention that most of these KPIs behave differently in case the user is in an indoor or an outdoor environment.

B. Realizing the Tactile Internet

For the rest of this section we will discuss recent progress in mobile networks towards delivering reliable low-latency communication for realization of the 5G Tactile Internet. Such developments are:

- *Software Defined Networking (SDN)*: By decoupling control and the data plane, and providing logically centralized control, SDN will be one of the key components of the 5G network. The centralized control allows for easier management of traffic within the network [216], [217], while taking advantage of the abstraction, mobility can be handled more reliably and with incurring less latency [218]. Furthermore, the software-based nature and the programmability enable delivery of QoS based on granular and flow-based policies [219], [220].
- *Network Function Virtualization (NFV)*: The virtualization and softwarization of network functions drastically decreases the dependency on hardware and therefore increases the scalability and reliability of the network. It is also easier to share resources among different network functions and also transfer network functions across the network in order to optimize a service's performance in terms of latency [221].
- *Mobile Edge Computing (MEC)*: While allowing mobility, a remotely located network of servers, either physical or both physical and virtual, is responsible for processing and storing data from a mobile device, enhancing the capabilities of a service or application, as well as acting as a computation offloading mechanism for the mobile device [222]. A relevant expansion of MCC related to haptic communication is cloud computing for mobile robotics. In this case, the cloud is used for off-loading computations (e.g. for stability control) from the remote robot

[223]. The previously mentioned NFV is a complimentary technology to Mobile Cloud Computing inside the 5G technology framework which allows optimal distribution of "intelligence" inside the network.

- *New Radio*: The new radio standards will enable services with diverse latency requirements. This will be primarily implemented by allowing a scalable Transmission Time Interval (TTI) and a redesign of the sub-frame (SF) making it easier to support a variety of services. LTE standards can currently offer 10 ms to 20 ms round trip time (between air interfaces only) using a 1 ms TTI. Nonetheless, 5G requirements demand a user plane end-to-end latency of less than 1 ms [224]. Furthermore, the deployment of Massive MIMO will ensure that the bit-error-rate (BER) will be kept at minimum for reliable low-latency communication[225].
- *Dual Connectivity*: Extra reliability in heterogeneous networks will be provided by decoupling uplink (UL) and downlink (DL) connections [226].

Radio resource allocation for haptic devices in LTE-A systems has been proposed in [227], in the scope of optimizing power and resource block allocation for both UL and DL channels. In [228], by taking into consideration the traffic patterns of haptic communication systems, soft resource reservation is proposed in order to reduce latency caused by the LTE scheduling request (SR) procedure in the UL channel.

In the case of SDN, methodologies have been developed for predicting performance by modeling the underlying network using queuing theory and network calculus (either stochastic or deterministic) making use of the network monitoring capabilities that SDN has. In this way it is possible to perform traffic shaping and path optimization based on the application requirements. Such mathematical tools have been presented in a survey on the analysis and modeling of SDN [229].

Prediction, in the context of anticipatory mobile networking, can offer benefits in other various areas as well, such as improving mobility management, decreasing latency and improving reliability with optimized resource allocation. This will offer the possibility to high mobility scenarios to become reality [230].

An implementation of a network coding strategy deployed using Virtual Network Functions in combination with an SDN controller was shown in [231]. The authors claim that random linear network coding not only increases the reliability of the communication but also positively affects the reduction of latency, although even in the case of lossless 3-hop communication network and an 8 Mb/s channel rate, the minimum latency achieved is 100 ms.

Since teleoperation with force feedback can be classified as a latency-sensitive application, the aforementioned technologies will be used to provide low-latency connectivity to users of various types of applications with low latency requirements.

VII. LESSONS LEARNED AND FUTURE CHALLENGES

Without a doubt, teleoperation is an ever-evolving field mainly combining robotics, telecommunications and data processing. According to [232], new and improved technologies

TABLE IV
CLASSIFICATION 5G USE CASES WITH EXAMPLES AND THEIR CORRESPONDING REQUIREMENTS FOR THE MAIN KPIS

Use case family	Traffic scenario examples	Main KPIS	Requirements
Higher reliability, availability & lower latency	<ul style="list-style-type: none"> • Medical treatment in ambulance • Low-latency industrial applications • Telemedicine cloud applications 	e2e latency Reliability Availability Mobility Data rate	≤ 1 ms $\geq 99,999\%$ $\approx 100\%$ ≥ 120 km/h 10s of Mbps per device
Very low latency	<ul style="list-style-type: none"> • Human interaction, Immersive VR, Remote healthcare, Telementoring 	e2e latency	1 ms one-way
Mission critical services	<ul style="list-style-type: none"> • Prioritized access when: the network is congested, simpler access procedures or guaranteed QoS are needed 	e2e latency Reliability Security	down to 1 ms $\approx 100\%$ max. confidentiality & integrity
Higher reliability & lower latency	<ul style="list-style-type: none"> • Unmanned Aerial Vehicles (UAVs) & Ground-based Vehicles • VR/AR applications • Cloud robotics • Industrial applications/ Power plants 	e2e latency Reliability Data rate Energy efficiency	1 ms min. 99,999% 250 Mb/s max. Various or NA
Higher accuracy positioning	<ul style="list-style-type: none"> • Outdoor positioning (high speed moving) • Indoor/Outdoor positioning (low speed moving) • UAV positioning for critical applications 	Accuracy e2e latency Mobility	≤ 3 m for 80% of occasions ≤ 10 ms to 15 ms two-way ≈ 280 km/h (cars)
Higher availability	<ul style="list-style-type: none"> • Secondary connectivity for emergencies (mobile-to-satellite) 	Coverage	Service continuity

are needed for Tactile Internet applications. The next steps of research work will help in enhancing the user experience and the effectiveness of the teleoperation systems.

Various control and communication approaches, as reviewed in the previous sections, have been developed to address the challenges of haptic communication for time-delayed teleoperation. So far, the control and communication aspects have been studied mainly independently and by abstracting or neglecting important properties of the underlying communication network. The implementation of teleoperation systems using realistic communication infrastructure, including wired or wireless IP networks, requires a more holistic view. The application in real-world packet-switched networks requires the joint consideration of control and communication aspects to achieve a stable, transparent and efficient system design. Furthermore, the state-of-the-art architectures differ in their robustness towards different network QoS parameters and artifacts introduced into the system. To date, there is neither a common understanding about the preferred architecture for certain QoS parameters, nor generalisable results about the required QoS parameters to achieve a certain teleoperation quality.

According to current technology trends, haptic interfaces are to be used from devices connected to mobile networks. Therefore, it is essential to explore further how teleoperation systems can be optimally integrated into the next generation (5G) mobile networks. This includes the optimization of the communication channel by investigating the mobile network infrastructure and the development of new protocols and evaluation metrics based on precise traffic models. In Figure 7,

we show the main challenges as described in previous sections of this survey in robotics, data processing and networking with a focus on the upcoming 5G network infrastructure. Further discussion on future goals is as follows:

1) *Improved and standardized network protocols*

As shown in Section III, there is a lot of room for improvement concerning the use of protocols in application, transport or other layers involved. This is made even more complicated by the fact that haptic communication in many cases needs to be secure, therefore, we need new methodologies that will not have a negative impact in the QoE of the user.

2) *Joint communication and control approaches for bilateral teleoperation*

High-quality bilateral teleoperation requires the joint orchestration of control and communication approaches to cope with limitations such as restricted transmission capacity, time-varying delay and random or bursty packet losses. So far, the number of studies that jointly consider stability-ensuring control and haptic data communication (including data reduction) is limited. Therefore, there are other combinations to be studied.

One of the future challenges is to fill the gaps in Table III, by combining haptic data reduction with the existing control approaches for bilateral teleoperation. The focus is real world communication with time-varying delay and packet loss. Having a set of different control and communication approaches to implement teleoperation systems is important, because they vary in their robustness towards certain QoS parameters (e.g. delay, delay variation or packet loss).

3) System performance as a function of the offered Quality-of-Service

Different control and communication approaches lead to different types of artifacts. Furthermore, their performance also varies between tasks (e.g. free space versus contact, soft objects versus rigid surface, etc.). To date, there is no common understanding about the preferred architecture for certain QoS parameters or tasks.

4) Privacy

It is obvious that in the future generations of the Internet, operators will have a more active role in acquiring and processing user data, especially since prediction will play a major role in optimizing the QoS offered by the network [230]. Furthermore, prioritization of network traffic raises issues of net neutrality which need to be further addressed so that appropriate legislation can be implemented.

5) Haptic Devices

The development of haptic interfaces and actuators that will allow the natural and more precise execution and replication of the desired user movement, but also improved force feedback experience.

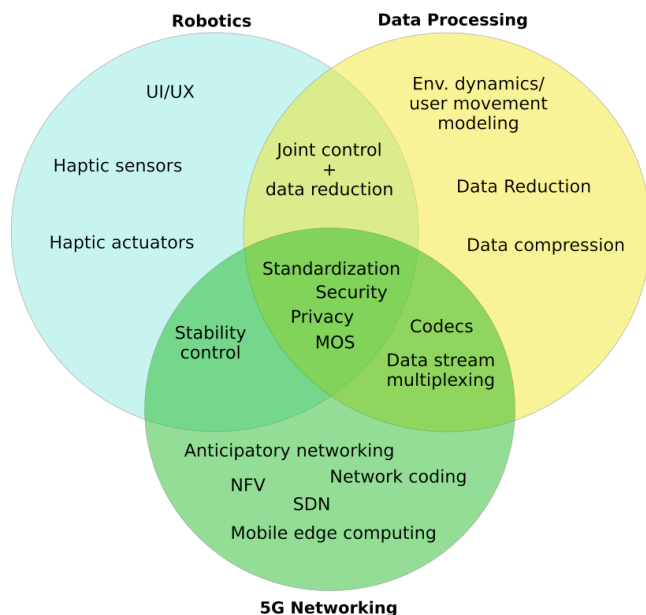

Figure 7. The main challenges in haptic communication over 5G network.

Future work could focus on defining objective system performance metrics, which will allow us to analyze and to compare different control and communication approaches for bilateral teleoperation systems.

Figure 8 (a) illustrates a hypothetical performance measurement for three control schemes in different network conditions. The set of control schemes and communication approaches include the schemes reviewed in Sections III and V and their potential variations. The system performance metrics Q_i can represent the quality of control (QoC), the quality of experience (QoE), the quality of task (QoT) or QoS-related characteristics as illustrated in Figure 8 (b).

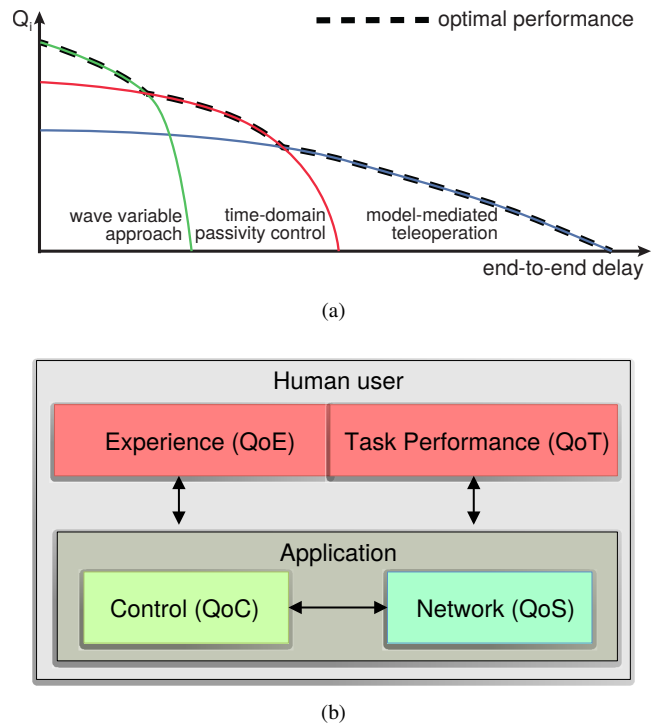

Figure 8. (a) Hypothetical performance measure for three control schemes as a function of the end-to-end delay. (b) Various system performance measures can be applied to objectively compare the quality of different control and communication approaches.

VIII. CONCLUSIONS

Haptic communication for bilateral teleoperation systems is among technologies which are starting to be adopted by an increasing number of immersive Internet applications. It will gain great benefits from the development of communication infrastructures such as the fifth generation of mobile networks (5G). Following the requirements of haptic communication over the Internet, this survey paper documents the fundamentals of haptic communication over the Internet and the latest advances which will allow the user to experience high quality immersion. This paper also focuses on the three main research interests, namely data compression and reduction, robust stability control, and multi-modal data streaming over the Internet.

Firstly, we made an introduction to the Tactile Internet and the impact of haptic communication in our everyday lives in the near future. We also described the requirements and environment dynamics for teleoperation systems. Next, a general introduction of teleoperation systems was presented, including the widely-used haptic devices and the challenges of teleoperation systems at present. Moreover, to the best of our knowledge, all transport and application layer protocols that can assist in multi-modal communication were listed and qualitatively evaluated, also focusing on haptic, video and audio data stream management and synchronization. In addition, we discussed QoS provisioning as well as the common network performance parameters. Furthermore, the main and also latest methods on haptic data reduction over packet-

switched networks were mentioned. Additionally, we surveyed research work that deals with robust stability of bilateral teleoperation systems. We also presented how the stability-ensuring control schemes have been combined with haptic data reduction techniques. The next section was dedicated to presenting the latest progress in 5G networking infrastructure from the point-of-view of haptic communication. Finally, we presented a summary of the lessons learned from this survey as well as a discussion on the future challenges of haptic communication over 5G networks.

ACKNOWLEDGMENT

This work is partially supported by Engineering and Physical Science Research Council (EPSRC award reference 1667394), the Ericsson 5G and Tactile Internet industry grant to King's College London and the German Research Foundation (DFG) under the project STE 1093/8-1.

REFERENCES

- [1] G. Fettweis, "The tactile internet: Applications and challenges," *Vehicular Technology Magazine*, vol. 9, no. 1, pp. 64–70, Mar 2014.
- [2] A. Aijaz, M. Dohler, A. H. Aghvami, V. Friderikos, and M. Frodigh, "Realizing the tactile internet: Haptic communications over next generation 5g cellular networks," *CoRR*, vol. abs/1510.02826, 2015. [Online]. Available: <http://arxiv.org/abs/1510.02826>
- [3] M. Simsek, A. Aijaz, M. Dohler, J. Sachs, and G. Fettweis, "5g-enabled tactile internet," *IEEE Journal on Selected Areas in Communications*, vol. PP, no. 99, pp. 1–1, 2016.
- [4] J. Cha, Y. S. Ho, Y. Kim, J. Ryu, and I. Oakley, "A framework for haptic broadcasting," *IEEE MultiMedia*, vol. 16, no. 3, pp. 16–27, July 2009.
- [5] S. Lederman and R. Klatzky, "Haptic perception: A tutorial," *Attention, Perception, & Psychophysics*, vol. 71, no. 7, pp. 1439–1459, 2009. [Online]. Available: <http://dx.doi.org/10.3758/APP.71.7.1439>
- [6] D. Lawrence, "Stability and transparency in bilateral teleoperation," *Robotics and Automation, IEEE Transactions on*, vol. 9, no. 5, pp. 624–637, Oct 1993.
- [7] M. Maier, M. Chowdhury, B. P. Rimal, and D. P. Van, "The tactile internet: vision, recent progress, and open challenges," *IEEE Communications Magazine*, vol. 54, no. 5, pp. 138–145, May 2016.
- [8] M. Agiwal, A. Roy, and N. Saxena, "Next generation 5g wireless networks: A comprehensive survey," *IEEE Communications Surveys Tutorials*, vol. 18, no. 3, pp. 1617–1655, thirdquarter 2016.
- [9] A. J. Davison, "Real-time simultaneous localisation and mapping with a single camera," in *Proceedings of the Ninth IEEE International Conference on Computer Vision - Volume 2*, ser. ICCV '03. Washington, DC, USA: IEEE Computer Society, 2003, pp. 1403–. [Online]. Available: <http://dl.acm.org/citation.cfm?id=946247.946734>
- [10] X. Shen, J. Zhou, A. El Saddik, and N. D. Georganas, "Architecture and evaluation of tele-haptic environments," in *Distributed Simulation and Real-Time Applications, 2004. DS-RT 2004. Eighth IEEE International Symposium on*, Oct 2004, pp. 53–60.
- [11] P. F. Hokayem and M. W. Spong, "Bilateral teleoperation: An historical survey," *Automatica*, vol. 42, no. 12, pp. 2035 – 2057, 2006. [Online]. Available: <http://www.sciencedirect.com/science/article/pii/S0005109806002871>
- [12] J. Lee and S. Payandeh, *Haptic Teleoperation Systems: Signal Processing Perspective*. Springer International Publishing, 2015.
- [13] T. B. Sheridan, "Space teleoperation through time delay: review and prognosis," *IEEE Transactions on Robotics and Automation*, vol. 9, no. 5, pp. 592–606, Oct 1993.
- [14] N. Pavon-Pulido, J. Lopez-Riquelme, J. Pinuaga-Cascales, J. Ferruz-Melero, and R. Morais Dos Santos, "Cybi: A smart companion robot for elderly people: Improving teleoperation and telepresence skills by combining cloud computing technologies and fuzzy logic," in *Autonomous Robot Systems and Competitions (ICARSC), 2015 IEEE International Conference on*, April 2015, pp. 198–203.
- [15] D. V. D. Berg, R. Glans, D. D. Koning, F. A. Kuipers, J. Lugtenburg, K. Polachan, P. T. Venkata, C. Singh, B. Turkovic, and B. V. Wijk, "Challenges in haptic communications over the tactile internet," *IEEE Access*, vol. 5, pp. 23 502–23 518, 2017.
- [16] K. Zareinia, Y. Maddahi, C. Ng, N. Sepehri, and G. R. Sutherland, "Performance evaluation of haptic hand-controllers in a robot-assisted surgical system," *The International Journal of Medical Robotics and Computer Assisted Surgery*, vol. 11, no. 4, pp. 486–501, 2015. [Online]. Available: <http://dx.doi.org/10.1002/rcs.1637>
- [17] M. Aiple and A. Schiele, "Pushing the limits of the CyberGrasp™ for haptic rendering," in *Robotics and Automation (ICRA), 2013 IEEE International Conference on*, May 2013, pp. 3541–3546.
- [18] L. Winfield, J. Glassmire, J. Colgate, and M. Peshkin, "T-pad: Tactile pattern display through variable friction reduction," in *EuroHaptics Conference, 2007 and Symposium on Haptic Interfaces for Virtual Environment and Teleoperator Systems. World Haptics 2007. Second Joint*, March 2007, pp. 421–426.
- [19] NeuroDigital Technologies, "Gloveone," <https://www.neurodigital.es/>.
- [20] Z. Kappasov, J.-A. Corrales, and V. Perdereau, "Tactile sensing in dexterous robot hands review," *Robotics and Autonomous Systems*, vol. 74, Part A, pp. 195 – 220, 2015. [Online]. Available: <http://www.sciencedirect.com/science/article/pii/S0921889015001621>
- [21] A. El Saddik, "C-HAVE: Collaborative haptic audio visual environments and systems," *Multimedia Systems*, vol. 13, no. 4, pp. 251–251, 2008. [Online]. Available: <http://dx.doi.org/10.1007/s00530-007-0102-0>
- [22] J. Colgate and J. Brown, "Factors affecting the z-width of a haptic display," in *Robotics and Automation, 1994. Proceedings, 1994 IEEE International Conference on*, May 1994, pp. 3205–3210 vol.4.
- [23] H. Tan, J. Radcliffe, B. N. Ga, H. Z. Tan, B. Eberman, M. A. Srinivasan, and B. Cheng, "Human factors for the design of force-reflecting haptic interfaces," 1994.
- [24] J. E. Colgate and G. G. Schenkel, "Passivity of a class of sampled-data systems: Application to haptic interfaces," *Journal of Robotic Systems*, vol. 14, no. 1, pp. 37–47, 1997.
- [25] J. J. Abbott and A. M. Okamura, "Effects of position quantization and sampling rate on virtual-wall passivity," *IEEE Transactions on Robotics*, vol. 21, no. 5, pp. 952–964, Oct 2005.
- [26] N. Diolaiti, G. Niemeyer, F. Barbagli, and J. K. Salisbury, "Stability of haptic rendering: Discretization, quantization, time delay, and coulomb effects," *IEEE Transactions on Robotics*, vol. 22, no. 2, pp. 256–268, April 2006.
- [27] E. Steinbach, S. Hirche, M. Ernst, F. Brandl, R. Chaudhari, J. Kammerl, and I. Vittorias, "Haptic communications," *Proceedings of the IEEE*, vol. 100, no. 4, pp. 937–956, April 2012.
- [28] J. Forsslund, S. Chan, J. Selesnick, K. Salisbury, R. G. Silva, and N. H. Blevins, "The effect of haptic degrees of freedom on task performance in virtual surgical environments," in *MMVR*, ser. Studies in Health Technology and Informatics, J. D. Westwood, S. W. Westwood, L. Fellnder-Tsai, R. S. Haluck, R. A. Robb, S. Senger, and K. G. Vosburgh, Eds., vol. 184. IOS Press, 2013, pp. 129–135.
- [29] V. Nitsch and B. Farber, "A meta-analysis of the effects of haptic interfaces on task performance with teleoperation systems," *IEEE Transactions on Haptics*, vol. 6, no. 4, pp. 387–398, 2013.
- [30] A. Mora and A. Barrientos, "An experimental study about the effect of interactions among functional factors in performance of telemanipulation systems," *Control Engineering Practice*, vol. 15, no. 1, pp. 29 – 41, 2007. [Online]. Available: <http://www.sciencedirect.com/science/article/pii/S09670666106000359>
- [31] B. Cizmeci, R. Chaudhari, X. Xu, N. Alt, and E. Steinbach, "A visual-haptic multiplexing scheme for teleoperation over constant-birate communication links," in *Haptics: Neuroscience, Devices, Modeling, and Applications*, ser. Lecture Notes in Computer Science, M. Auvray and C. Duriez, Eds. Springer Berlin Heidelberg, 2014, vol. 8619, pp. 131–138. [Online]. Available: http://dx.doi.org/10.1007/978-3-662-44196-1_17
- [32] Z. Cen, M. Mutka, Y. Liu, A. Goradia, and N. Xi, "Qos management of supermedia enhanced teleoperation via overlay networks," in *Intelligent Robots and Systems, 2005. (IROS 2005). 2005 IEEE/RSJ International Conference on*, Aug 2005, pp. 1630–1635.
- [33] T.-C. Yang, "Networked control system: a brief survey," *Control Theory and Applications, IEE Proceedings -*, vol. 153, no. 4, pp. 403–412, July 2006.
- [34] Q. Dang, B. Allouche, A. Dequidt, L. Vermeiren, and V. Dubreucq, "Real-time control of a force feedback haptic interface via ethercat

- fieldbus,” in *Industrial Technology (ICIT), 2015 IEEE International Conference on*, March 2015, pp. 441–446.
- [35] S. Tzafestas, *Web-Based Control and Robotics Education*, ser. Intelligent Systems, Control and Automation: Science and Engineering, Springer Netherlands, 2009.
- [36] B. Briscoe, A. Brunstrom, A. Petlund, D. Hayes, D. Ros, I. J. Tsang, S. Gjessing, G. Fairhurst, C. Griwodz, and M. Welzl, “Reducing internet latency: A survey of techniques and their merits,” *IEEE Communications Surveys Tutorials*, vol. 18, no. 3, pp. 2149–2196, thirdquarter 2016.
- [37] Z. Shi, H. Zou, M. Rank, L. Chen, S. Hirche, and H. J. Muller, “Effects of packet loss and latency on the temporal discrimination of visual-haptic events,” *IEEE Transactions on Haptics*, vol. 3, no. 1, pp. 28–36, Jan 2010.
- [38] C. Seo, J.-P. Kim, J. Kim, H.-S. Ahn, and J. Ryu, “Robustly stable bilateral teleoperation under time-varying delays and data losses: an energy-bounding approach,” *Journal of Mechanical Science and Technology*, vol. 25, no. 8, p. 2089, Sep 2011. [Online]. Available: <https://doi.org/10.1007/s12206-011-0523-8>
- [39] P. Huang and Y. Ishibashi, “QoS control and QoE assessment in multi-sensory communications with haptics,” *IEICE Transactions on Communications*, vol. 96, no. 2, pp. 392–403, 2013.
- [40] G. Kokkonis, K. Psannis, M. Roumeliotis, S. Kontogiannis, and Y. Ishibashi, “Evaluating transport and application layer protocols for haptic applications,” in *Haptic Audio Visual Environments and Games (HAVE), 2012 IEEE International Workshop on*, Oct 2012, pp. 66–71.
- [41] K. M. Yap, A. Marshall, and W. Yu, “Providing qos for distributed haptic virtual environments in ip networks,” in *Proceedings of the First International Conference on Immersive Telecommunications*, ser. ImmersCom '07. ICST, Brussels, Belgium, Belgium: ICST (Institute for Computer Sciences, Social-Informatics and Telecommunications Engineering), 2007, pp. 13:1–13:6. [Online]. Available: <http://dl.acm.org/citation.cfm?id=1538981.1538998>
- [42] G. Kokkonis, K. Psannis, M. Roumeliotis, and S. Kontogiannis, “A survey of transport protocols for haptic applications,” in *Informatics (PCI), 2012 16th Panhellenic Conference on*, Oct 2012, pp. 192–197.
- [43] J.-y. Lee and S. Payandeh, “A layered protocol architecture for haptic teleoperation systems based on the bayesian approach,” in *Haptic Teleoperation Systems*. Springer International Publishing, 2015, pp. 35–59. [Online]. Available: http://dx.doi.org/10.1007/978-3-319-19557-5_4
- [44] N. Suzuki and S. Katsura, “Investigation of transport layer protocols for wireless haptic communication system,” in *System Integration (SII), 2011 IEEE/SICE International Symposium on*, Dec 2011, pp. 509–514.
- [45] S. Dodeller and N. Georganas, “Transport layer protocols for tele-haptics update messages,” in *Proc. 22nd Biennial Symposium on Communications, Queens Univeristy, Canada*, 2004, pp. 191–193.
- [46] L. Ping, L. Wenjuan, and S. Zengqi, “Transport layer protocol re-configuration for network-based robot control system,” in *Networking, Sensing and Control, 2005. Proceedings. 2005 IEEE*, March 2005, pp. 1049–1053.
- [47] Z. Cen, M. W. Mutka, D. Zhu, and N. Xi, “Supermedia transport for teleoperations over overlay networks,” in *NETWORKING 2005. Networking Technologies, Services, and Protocols; Performance of Computer and Communication Networks; Mobile and Wireless Communications Systems*, R. Boutaba, K. Almeroth, R. Puigjaner, S. Shen, and J. P. Black, Eds. Berlin, Heidelberg: Springer Berlin Heidelberg, 2005, pp. 1409–1412.
- [48] Y. Uchimura, K. Ohnishi, and T. Yakoh, “Bilateral robot system on the real time network structure,” in *Advanced Motion Control, 2002. 7th International Workshop on*, 2002, pp. 63–68.
- [49] R. Wirz, M. Ferre, R. Marn, J. Barrio, J. Claver, and J. Ortego, “Efficient transport protocol for networked haptics applications,” in *Haptics: Perception, Devices and Scenarios*, ser. Lecture Notes in Computer Science, M. Ferre, Ed. Springer Berlin Heidelberg, 2008, vol. 5024, pp. 3–12. [Online]. Available: http://dx.doi.org/10.1007/978-3-540-69057-3_1
- [50] A. Boukerche and H. Maamar, “An efficient hybrid multicast transport protocol for collaborative virtual environment with networked haptic,” in *Haptic Audio Visual Environments and their Applications, 2006. HAVE 2006. IEEE International Workshop on*, 2006, pp. 78–83.
- [51] H. Kim and J.-H. Ryu, “A study on the effect of haptic to video time-delay on teleoperation and a comment for improving the performance,” in *Control, Automation and Systems (ICCAS), 2011 11th International Conference on*, Oct 2011, pp. 1329–1332.
- [52] Z. Yuan, T. Bi, G.-M. Muntean, and G. Ghinea, “Perceived synchronization of mulsemmedia services,” *Multimedia, IEEE Transactions on*, vol. 17, no. 7, pp. 957–966, July 2015.
- [53] Z. Yuan, G. Ghinea, and G.-M. Muntean, “Beyond multimedia adaptation: Quality of experience-aware multi-sensorial media delivery,” *Multimedia, IEEE Transactions on*, vol. 17, no. 1, pp. 104–117, Jan 2015.
- [54] H. King, B. Hannaford, J. Kammerl, and E. Steinbach, “Establishing multimodal telepresence sessions using the session initiation protocol (sip) and advanced haptic codecs,” in *Haptics Symposium, 2010 IEEE*, March 2010, pp. 321–325.
- [55] M. Mauve, V. Hilt, C. Kuhmunch, and W. Effelsberg, “RTP/I-toward a common application level protocol for distributed interactive media,” *Multimedia, IEEE Transactions on*, vol. 3, no. 1, pp. 152–161, Mar 2001.
- [56] Y. Lim, “MMT, new alternative to MPEG-2 TS and RTP,” in *Broadband Multimedia Systems and Broadcasting (BMSB), 2013 IEEE International Symposium on*, June 2013, pp. 1–5.
- [57] K. Venkatraman, S. Vellingiri, B. Prabhakaran, and N. Nguyen, “Mpeg media transport (mmt) for 3d tele-immersion systems,” in *Multimedia (ISM), 2014 IEEE International Symposium on*, Dec 2014, pp. 279–282.
- [58] Q. Nasir and E. Khalil, “Perception based adaptive haptic communication protocol (pahcp),” in *Computer Systems and Industrial Informatics (ICCSII), 2012 International Conference on*, Dec 2012, pp. 1–6.
- [59] H. Al Osman, M. Eid, R. Iglesias, and A. El Saddik, “ALPHAN: Application layer protocol for haptic networking,” in *Haptic, Audio and Visual Environments and Games, 2007. HAVE 2007. IEEE International Workshop on*, Oct 2007, pp. 96–101.
- [60] M. Eid, J. Cha, and A. E. Saddik, “Admux: An adaptive multiplexer for haptic-audio-visual data communication,” *IEEE Transactions on Instrumentation and Measurement*, vol. 60, no. 1, pp. 21–31, Jan 2011.
- [61] H. H. King, K. Tadano, R. Donlin, D. Friedman, M. J. H. Lum, V. Asch, C. Wang, K. Kawashima, and B. Hannaford, “Preliminary protocol for interoperable telesurgery,” in *2009 International Conference on Advanced Robotics*, June 2009, pp. 1–6.
- [62] V. Gokhale, S. Chaudhuri, and O. Dabeer, “HoIP: A point-to-point haptic data communication protocol and its evaluation,” in *Communications (NCC), 2015 Twenty First National Conference on*, Feb 2015, pp. 1–6.
- [63] Z. Cen, M. W. Mutka, D. Zhu, and N. Xi, *NETWORKING 2005. Networking Technologies, Services, and Protocols; Performance of Computer and Communication Networks; Mobile and Wireless Communications Systems: 4th International IFIP-TC6 Networking Conference, Waterloo, Canada, May 2-6, 2005. Proceedings*. Berlin, Heidelberg: Springer Berlin Heidelberg, 2005, ch. Supermedia Transport for Teleoperations over Overlay Networks, pp. 1409–1412. [Online]. Available: http://dx.doi.org/10.1007/11422778_126
- [64] G. S. Lee and B. Thuraisingham, “Cyberphysical systems security applied to telesurgical robotics,” *Comput. Stand. Interfaces*, vol. 34, no. 1, pp. 225–229, Jan. 2012. [Online]. Available: <https://doi.org/10.1016/j.csi.2011.09.001>
- [65] M. E. Tozal, Y. Wang, E. Al-Shaer, K. Sarac, B. Thuraisingham, and B.-T. Chu, “On secure and resilient telesurgery communications over unreliable networks,” in *Computer Communications Workshops (INFOCOM WKSHPS), 2011 IEEE Conference on*, April 2011, pp. 714–719.
- [66] R. Braden, D. Clark, and S. Shenker, “RFC 1633 : Integrated Services in the Internet Architecture: an Overview,” IETF, Tech. Rep., 1994. [Online]. Available: www.ietf.org/rfc/rfc1633.txt
- [67] K. Nichols, S. Blake, F. Baker, and D. Black, “Definition of the differentiated services field (ds field) in the ipv4 and ipv6 headers,” United States, Tech. Rep., 1998.
- [68] D. Kreutz, F. Ramos, P. Esteves Verissimo, C. Esteve Rothenberg, S. Azodolmolky, and S. Uhlig, “Software-defined networking: A comprehensive survey,” *Proceedings of the IEEE*, vol. 103, no. 1, pp. 14–76, 2015.
- [69] F. Sardis, M. Condoluci, T. Mahmoodi, and M. Dohler, “Can QoS be dynamically manipulated using End-Device Initialization?” in *IEEE International Conference on Communications Workshops (ICC)*, May 2016, pp. 448–454.
- [70] R. Durner, A. Blenk, and W. Kellerer, “Performance study of dynamic qos management for openflow-enabled sdn switches,” in *IEEE/ACM International Symposium on Quality of Service (IWQoS)*, 2015.
- [71] H. Sandberg, S. Amin, and K. H. Johansson, “Cyberphysical security in networked control systems: An introduction to the issue,” *IEEE Control Systems*, vol. 35, no. 1, pp. 20–23, Feb 2015.

- [72] A. Abou El Kalam, A. Ferreira, and F. Kratz, "Bilateral teleoperation system using qos and secure communication networks for telemedicine applications," *Systems Journal, IEEE*, vol. PP, no. 99, pp. 1–12, 2015.
- [73] A. Burg, A. Chattopadhyay, and K. Y. Lam, "Wireless communication and security issues for cyber-physical systems and the internet-of-things," *Proceedings of the IEEE*, vol. 106, no. 1, pp. 38–60, Jan 2018.
- [74] T. Brooks, "Telerobotic response requirements," in *Systems, Man and Cybernetics, 1990. Conference Proceedings., IEEE International Conference on*, Nov 1990, pp. 113–120.
- [75] K. Shimoga, "A survey of perceptual feedback issues in dexterous telemanipulation. i. finger force feedback," in *Virtual Reality Annual International Symposium, 1993., 1993 IEEE*, Sep 1993, pp. 263–270.
- [76] —, "A survey of perceptual feedback issues in dexterous telemanipulation. ii. finger touch feedback," in *Virtual Reality Annual International Symposium, 1993., 1993 IEEE*, Sep 1993, pp. 271–279.
- [77] P. Otanez, J. R. Moyne, and D. Tilbury, "Using deadbands to reduce communication in networked control systems," in *American Control Conference, 2002. Proceedings of the 2002*, vol. 4, 2002, pp. 3015–3020 vol.4.
- [78] P. Hinterseer, E. Steinbach, S. Hirche, and M. Buss, "A novel, psychophysically motivated transmission approach for haptic data streams in telepresence and teleaction systems," in *Acoustics, Speech, and Signal Processing, 2005. Proceedings. (ICASSP '05). IEEE International Conference on*, vol. 2, March 2005, pp. ii/1097–ii/1100 Vol. 2.
- [79] P. Hinterseer, S. Hirche, S. Chaudhuri, E. Steinbach, and M. Buss, "Perception-based data reduction and transmission of haptic data in telepresence and teleaction systems," *Signal Processing, IEEE Transactions on*, vol. 56, no. 2, pp. 588–597, Feb 2008.
- [80] C. Shahabi, A. Ortega, and M. Kolahdouzan, "A comparison of different haptic compression techniques," in *Multimedia and Expo, 2002. ICME '02. Proceedings. 2002 IEEE International Conference on*, vol. 1, 2002, pp. 657–660 vol.1.
- [81] Y. You and M. Y. Sung, "Haptic data transmission based on the prediction and compression," in *Communications, 2008. ICC '08. IEEE International Conference on*, May 2008, pp. 1824–1828.
- [82] H. Tanaka and K. Ohnishi, "Haptic data compression/decompression using dct for motion copy system," in *Mechatronics, 2009. ICM 2009. IEEE International Conference on*, April 2009, pp. 1–6.
- [83] A. Kuzu, E. A. Baran, S. Bogosyan, M. Gokasan, and A. Sabanovic, "Wavelet packet transform-based compression for teleoperation," *Proceedings of the Institution of Mechanical Engineers, Part I: Journal of Systems and Control Engineering*, vol. 229, no. 7, pp. 639–651, 2015. [Online]. Available: <http://pii.sagepub.com/content/229/7/639.abstract>
- [84] E. Steinbach, S. Hirche, J. Kammerl, I. Vittorias, and R. Chaudhuri, "Haptic data compression and communication," *Signal Processing Magazine, IEEE*, vol. 28, no. 1, pp. 87–96, Jan 2011.
- [85] V. Nitsch, B. Farber, L. Geiger, P. Hinterseer, and E. Steinbach, "An experimental study of lossy compression in a real telepresence and teleaction system," in *Haptic Audio visual Environments and Games, 2008. HAVE 2008. IEEE International Workshop on*, Oct 2008, pp. 75–80.
- [86] E. Weber, *De Pulsu, resorptione, auditu et tactu: Annotationes anatomicae et physiologicae ...*, ser. Annotationes anatomicae et physiologicae. C.F. Koehler, 1834. [Online]. Available: <https://books.google.co.uk/books?id=bdI-AAAAYAAJ>
- [87] J. Awed, I. Elhajj, and N. Slobodenyuk, "Haptic force perception in bimanual manipulation," in *Haptics: Perception, Devices, Mobility, and Communication*, ser. Lecture Notes in Computer Science, P. Isokoski and J. Springare, Eds. Springer Berlin Heidelberg, 2012, vol. 7283, pp. 1–6. [Online]. Available: http://dx.doi.org/10.1007/978-3-642-31404-9_1
- [88] S. Allin, Y. Matsuoka, and R. Klatzky, "Measuring just noticeable differences for haptic force feedback: implications for rehabilitation," in *Haptic Interfaces for Virtual Environment and Teleoperator Systems, 2002. HAPTICS 2002. Proceedings. 10th Symposium on*, 2002, pp. 299–302.
- [89] N. Sakr, J. Zhou, N. D. Georganas, J. Zhao, and E. Petriu, "Robust perception-based data reduction and transmission in telehaptic systems," in *EuroHaptics conference, 2009 and Symposium on Haptic Interfaces for Virtual Environment and Teleoperator Systems. World Haptics 2009. Third Joint*, March 2009, pp. 214–219.
- [90] A. Bhardwaj, O. Dabeer, and S. Chaudhuri, "Can we improve over weber sampling of haptic signals?" in *Information Theory and Applications Workshop (ITA), 2013*, Feb 2013, pp. 1–6.
- [91] A. Bhardwaj, S. Chaudhuri, and O. Dabeer, "Design and analysis of predictive sampling of haptic signals," *ACM Trans. Appl. Percept.*, vol. 11, no. 4, pp. 16:1–16:20, Dec. 2014. [Online]. Available: <http://doi.acm.org/10.1145/2670533>
- [92] P. Hinterseer, E. Steinbach, and S. Chaudhuri, "Model based data compression for 3d virtual haptic teleinteraction," in *Consumer Electronics, 2006. ICCE '06. 2006 Digest of Technical Papers. International Conference on*, Jan 2006, pp. 23–24.
- [93] P. Hinterseer, E. Steinbach, and S. Chaudhuri, "Perception-based compression of haptic data streams using kalman filters," in *Acoustics, Speech and Signal Processing, 2006. ICASSP 2006 Proceedings. 2006 IEEE International Conference on*, vol. 5, May 2006, pp. V–V.
- [94] N. Sakr, N. Georganas, J. Zhao, and X. Shen, "Motion and force prediction in haptic media," in *Multimedia and Expo, 2007 IEEE International Conference on*, July 2007, pp. 2242–2245.
- [95] F. Guo, C. Zhang, and Y. He, "Haptic data compression based on a linear prediction model and quadratic curve reconstruction," *Journal of Software*, vol. 9, no. 11, 2014. [Online]. Available: <http://ojs.academypublisher.com/index.php/jsw/article/view/jsw091127962803>
- [96] X. Xu, J. Kammerl, R. Chaudhuri, and E. Steinbach, "Hybrid signal-based and geometry-based prediction for haptic data reduction," in *Haptic Audio Visual Environments and Games (HAVE), 2011 IEEE International Workshop on*, Oct 2011, pp. 68–73.
- [97] S. Payandeh and J.-Y. Lee, "User-centered force signal processing for internet-based telemanipulation: An overview," in *Systems, Man and Cybernetics (SMC), 2014 IEEE International Conference on*, Oct 2014, pp. 3978–3983.
- [98] K. J. Kuchenbecker, J. Fiene, and G. Niemeyer, "Improving contact realism through event-based haptic feedback," *IEEE Transactions on Visualization and Computer Graphics*, vol. 12, no. 2, pp. 219–230, Mar. 2006. [Online]. Available: <http://dx.doi.org/10.1109/TVCG.2006.32>
- [99] W. McMahan, J. Romano, A. Abdul Rahuman, and K. Kuchenbecker, "High frequency acceleration feedback significantly increases the realism of haptically rendered textured surfaces," in *Haptics Symposium, 2010 IEEE*, March 2010, pp. 141–148.
- [100] A. Okamura, J. Dennerlein, and R. Howe, "Vibration feedback models for virtual environments," in *Robotics and Automation, 1998. Proceedings. 1998 IEEE International Conference on*, vol. 1, May 1998, pp. 674–679 vol.1.
- [101] K. J. Kuchenbecker, J. M. Romano, and W. McMahan, "Haptography: Capturing and recreating the rich feel of real surfaces." in *Int. Symp. on Robotics Research (invited paper)*, ser. Springer Tracts in Advanced Robotics, vol. 70. Springer, 2009, pp. 245–260.
- [102] V. Guruswamy, J. Lang, and W.-S. Lee, "fir filter models of haptic vibration textures," *Instrumentation and Measurement, IEEE Transactions on*, vol. 60, no. 1, pp. 93–103, Jan 2011.
- [103] S. Okamoto and Y. Yamada, "Perceptual properties of vibrotactile material texture: Effects of amplitude changes and stimuli beneath detection thresholds," in *System Integration (SII), 2010 IEEE/SICE International Symposium on*, Dec 2010, pp. 384–389.
- [104] J. Craig, "Difference threshold for intensity of tactile stimuli," *Perception & Psychophysics*, vol. 11, no. 2, pp. 150–152, 1972. [Online]. Available: <http://dx.doi.org/10.3758/BF03210362>
- [105] H. Pongrac, "Vibrotactile perception: examining the coding of vibrations and the just noticeable difference under various conditions," *Multimedia Systems*, vol. 13, no. 4, pp. 297–307, 2008. [Online]. Available: <http://dx.doi.org/10.1007/s00530-007-0105-x>
- [106] C. Hatzfeld and R. Werthschitzky, "Just noticeable differences of low-intensity vibrotactile forces at the fingertip," in *Haptics: Perception, Devices, Mobility, and Communication*, ser. Lecture Notes in Computer Science, P. Isokoski and J. Springare, Eds. Springer Berlin Heidelberg, 2012, vol. 7283, pp. 43–48. [Online]. Available: http://dx.doi.org/10.1007/978-3-642-31404-9_8
- [107] R. Chaudhuri, B. Çizmeçi, K. J. Kuchenbecker, S. Choi, and E. Steinbach, "Low bitrate source-filter model based compression of vibrotactile texture signals in haptic teleoperation," in *Proceedings of the 20th ACM International Conference on Multimedia*, ser. MM '12. New York, NY, USA: ACM, 2012, pp. 409–418. [Online]. Available: <http://doi.acm.org/10.1145/2393347.2393407>
- [108] I. T. Union and I. T. U. T. S. Sector, *Coding of Speech at 8 Kbit/s Using Conjugate-structure Algebraic-code-excited Linear-prediction (CS-ACELP): Reduced complexity 8 kbit/s CS-ACELP speech codec. Annex A*, ser. ITU-T recommendation. International Telecommunication Union, 1996. [Online]. Available: <https://www.itu.int/rec/T-REC-G.729/e>
- [109] R. Chaudhuri, C. Schuwerk, M. Danaei, and E. Steinbach, "Perceptual and bitrate-scalable coding of haptic surface texture signals," *Selected Topics in Signal Processing, IEEE Journal of*, vol. 9, no. 3, pp. 462–473, April 2015.

- [110] E. Zwicker and R. Feldtkeller, *Das Ohr als Nachrichtenempfänger*, ser. Monographien der elektrischen Nachrichtentechnik. Hirzel, 1967. [Online]. Available: <https://books.google.co.uk/books?id=kyZiQgAACAAJ>
- [111] A. Tatematsu, Y. Ishibashi, N. Fukushima, and S. Sugawara, "Qoe assessment in tele-operation with 3d video and haptic media," in *2011 IEEE International Conference on Multimedia and Expo*, July 2011, pp. 1–6.
- [112] X. Liu, M. Dohler, T. Mahmoodi, and H. Liu, "Challenges and opportunities for designing tactile codecs from audio codecs," in *2017 European Conference on Networks and Communications (EuCNC)*, June 2017, pp. 1–5.
- [113] C. Aldana, E. Nuno, and L. Basanez, "Control of bilateral teleoperators in the operational space without velocity measurements," in *Intelligent Robots and Systems (IROS), 2013 IEEE/RSJ International Conference on*, Nov 2013, pp. 5445–5450.
- [114] L. Chan, F. Naghdy, and D. Stirling, "Application of adaptive controllers in teleoperation systems: A survey," *Human-Machine Systems, IEEE Transactions on*, vol. 44, no. 3, pp. 337–352, June 2014.
- [115] P. Arcara and C. Melchiorri, "Control schemes for teleoperation with time delay: A comparative study," *Robotics and Autonomous Systems*, vol. 38, no. 1, pp. 49 – 64, 2002.
- [116] C. Passenberg, A. Peer, and M. Buss, "A survey of environment-, operator-, and task-adapted controllers for teleoperation systems," *Mechatronics*, vol. 20, no. 7, pp. 787 – 801, 2010, special Issue on Design and Control Methodologies in Telerobotics.
- [117] D. Lee, O. Martinez-Palafox, and M. W. Spong, "Bilateral teleoperation of multiple cooperative robots over delayed communication networks: Application," in *Proceedings of the 2005 IEEE International Conference on Robotics and Automation, ICRA 2005, April 18-22, 2005, Barcelona, Spain, 2005*, pp. 366–371. [Online]. Available: <http://dx.doi.org/10.1109/ROBOT.2005.1570146>
- [118] S. Sirouspour and P. Setoodeh, "Adaptive nonlinear teleoperation control in multi-master/multi-slave environments," in *Control Applications, 2005. CCA 2005. Proceedings of 2005 IEEE Conference on*, Aug 2005, pp. 1263–1268.
- [119] T. Maneewarn and P. Tothawornyueng, "Effects of system delay in passivity-based haptic system," in *Robotics, Automation and Mechatronics, 2006 IEEE Conference on*, Dec 2006, pp. 1–6.
- [120] N. Yasrebi and D. Constantinescu, "Passive wave variable control of haptic interaction with an unknown virtual environment," in *Robotics and Automation (ICRA), 2011 IEEE International Conference on*, May 2011, pp. 919–924.
- [121] K. Hashtrudi-Zaad and S. Salcudean, "Analysis and evaluation of stability and performance robustness for teleoperation control architectures," in *Robotics and Automation, 2000. Proceedings. ICRA '00. IEEE International Conference on*, vol. 4, 2000, pp. 3107–3113 vol.4.
- [122] W. Iida and K. Ohnishi, "Reproducibility and operability in bilateral teleoperation," in *Advanced Motion Control, 2004. AMC '04. The 8th IEEE International Workshop on*, March 2004, pp. 217–222.
- [123] R. Chaudhari, C. Schuwerk, V. Nitsch, E. Steinbach, and B. Frber, "Opening the haptic loop: Network degradation limits for haptic task performance," in *Haptic Audio Visual Environments and Games (HAVE), 2011 IEEE International Workshop on*, Oct 2011, pp. 56–61.
- [124] R. Anderson and M. Spong, "Bilateral control of teleoperators with time delay," *Automatic Control, IEEE Transactions on*, vol. 34, no. 5, pp. 494–501, May 1989.
- [125] M. Dyck, A. Jazayeri, and M. Tavakoli, "Is the human operator in a teleoperation system passive?" in *World Haptics Conference (WHC), 2013, April 2013*, pp. 683–688.
- [126] F. Buzan and T. Sheridan, "A model-based predictive operator aid for telemanipulators with time delay," in *Systems, Man and Cybernetics, 1989. Conference Proceedings., IEEE International Conference on*, Nov 1989, pp. 138–143 vol.1.
- [127] B. Hannaford, "A design framework for teleoperators with kinesthetic feedback," *Robotics and Automation, IEEE Transactions on*, vol. 5, no. 4, pp. 426–434, Aug 1989.
- [128] C. Secchi, S. Stramigioli, and C. Fantuzzi, "Digital passive geometric telemanipulation," in *Robotics and Automation, 2003. Proceedings. ICRA '03. IEEE International Conference on*, vol. 3, Sept 2003, pp. 3290–3295 vol.3.
- [129] J. Slotine and W. Li, *Applied Nonlinear Control*. Prentice Hall, 1991.
- [130] A. Jazayeri and M. Tavakoli, "Bilateral teleoperation system stability with non-passive and strictly passive operator or environment," *Control Engineering Practice*, vol. 40, pp. 45 – 60, 2015.
- [131] E. Nuño, L. Basaez, and R. Ortega, "Passivity-based control for bilateral teleoperation: A tutorial," *Automatica*, vol. 47, no. 3, pp. 485 – 495, 2011. [Online]. Available: <http://www.sciencedirect.com/science/article/pii/S0005109811000197>
- [132] D. Lee and P. Li, "Passive bilateral control and tool dynamics rendering for nonlinear mechanical teleoperators," *Robotics, IEEE Transactions on*, vol. 21, no. 5, pp. 936–951, Oct 2005.
- [133] E. Nuño, R. Ortega, N. Barabanov, and L. Basanez, "A globally stable pd controller for bilateral teleoperators," *Robotics, IEEE Transactions on*, vol. 24, no. 3, pp. 753–758, June 2008.
- [134] J. Wu, Y. Shi, J. Huang, and D. Constantinescu, "Stochastic stabilization for bilateral teleoperation over networks with probabilistic delays," *Mechatronics*, vol. 22, no. 8, pp. 1050 – 1059, 2012.
- [135] K. Abidi, Y. Yildiz, and B. E. Korpe, "Explicit adaptive time-delay compensation for bilateral teleoperation," in *Control and Decision Conference (CCDC), 2015 27th Chinese*, May 2015, pp. 3379–3383.
- [136] G. M. H. Leung, B. A. Francis, and J. Apkarian, "Bilateral controller for teleoperators with time delay via γ -synthesis," *IEEE Transactions on Robotics and Automation*, vol. 11, pp. 105–116, 1997.
- [137] A. Alfí, A. Khosravi, and A. Lari, "Swarm-based structure-specified controller design for bilateral transparent teleoperation systems via γ -synthesis," *IMA Journal of Mathematical Control and Information*, vol. 31, no. 1, pp. 111–136, 2014. [Online]. Available: <http://imamci.oxfordjournals.org/content/31/1/111.abstract>
- [138] J. Sheng and M. Spong, "Model predictive control for bilateral teleoperation systems with time delays," in *Electrical and Computer Engineering, 2004. Canadian Conference on*, vol. 4, May 2004, pp. 1877–1880 Vol.4.
- [139] Z. Li, X. Cao, and N. Ding, "Adaptive fuzzy control for synchronization of nonlinear teleoperators with stochastic time-varying communication delays," *Fuzzy Systems, IEEE Transactions on*, vol. 19, no. 4, pp. 745–757, Aug 2011.
- [140] Y. Yang, C. Hua, and X. Guan, "Synchronization control for bilateral teleoperation system with prescribed performance under asymmetric time delay," *Nonlinear Dynamics*, vol. 81, no. 1-2, pp. 481–493, 2015. [Online]. Available: <http://dx.doi.org/10.1007/s11071-015-2006-4>
- [141] I. Sarras, E. Nuo, M. Kinnaert, and L. Basaez, "Output-feedback control of nonlinear bilateral teleoperators," in *American Control Conference (ACC), 2012, June 2012*, pp. 3490–3495.
- [142] A. Jafari, M. Nabeel, and J. H. Ryu, "Multi degree-of-freedom input-to-state stable approach for stable haptic interaction," in *World Haptics Conference (WHC), 2015 IEEE*, June 2015, pp. 293–298.
- [143] H. Morimitsu and S. Katsura, "Circle theorem-based realization of nonlinear force control for teleoperation under time delay," in *Mechatronics (ICM), 2015 IEEE International Conference on*, March 2015, pp. 562–567.
- [144] K. Natori, T. Tsuji, K. Ohnishi, A. Hase, and K. Jezernik, "Time-delay compensation by communication disturbance observer for bilateral teleoperation under time-varying delay," *Industrial Electronics, IEEE Transactions on*, vol. 57, no. 3, pp. 1050–1062, March 2010.
- [145] A. Suzuki and K. Ohnishi, "Frequency-domain damping design for time-delayed bilateral teleoperation system based on modal space analysis," *Industrial Electronics, IEEE Transactions on*, vol. 60, no. 1, pp. 177–190, Jan 2013.
- [146] J. H. Park and H. C. Cho, "Sliding-mode controller for bilateral teleoperation with varying time delay," in *Advanced Intelligent Mechatronics, 1999. Proceedings. 1999 IEEE/ASME International Conference on*, 1999, pp. 311–316.
- [147] F. Llewellyn, "Some fundamental properties of transmission systems," *Proceedings of the IRE*, vol. 40, no. 3, pp. 271–283, March 1952.
- [148] C. Pacchierotti, A. Tirmizi, G. Bianchini, and D. Prattichizzo, "Enhancing the performance of passive teleoperation systems via cutaneous feedback," *IEEE transactions on haptics*, 2015.
- [149] G. Niemeyer and J.-J. Slotine, "Stable adaptive teleoperation," *Oceanic Engineering, IEEE Journal of*, vol. 16, no. 1, pp. 152–162, Jan 1991.
- [150] —, "Towards force-reflecting teleoperation over the internet," in *Robotics and Automation, 1998. Proceedings. 1998 IEEE International Conference on*, vol. 3, May 1998, pp. 1909–1915 vol.3.
- [151] D. Sun, F. Naghdy, and H. Du, "Application of wave-variable control to bilateral teleoperation systems: A survey," *Annual Reviews in Control*, vol. 38, no. 1, pp. 12–31, 2014.
- [152] A. Aziminejad, M. Tavakoli, R. Patel, and M. Moallem, "Wave-based time delay compensation in bilateral teleoperation: Two-channel versus four-channel architectures," in *American Control Conference, 2007. ACC '07, July 2007*, pp. 1449–1454.
- [153] M. Boukhnifer and A. Ferreira, "Stability and transparency for scaled teleoperation system," in *Intelligent Robots and Systems, 2006 IEEE/RSJ International Conference on*, Oct 2006, pp. 4217–4222.

- [154] M. Alise, R. Roberts, D. Repperger, C. Moore, and S. Tosunoglu, "On extending the wave variable method to multiple-dof teleoperation systems," *Mechatronics, IEEE/ASME Transactions on*, vol. 14, no. 1, pp. 55–63, Feb 2009.
- [155] Y. Ye and P. Liu, "Improving trajectory tracking in wave-variable-based teleoperation," *Mechatronics, IEEE/ASME Transactions on*, vol. 15, no. 2, pp. 321–326, April 2010.
- [156] E. Rodriguez-Seda and M. Spong, "A time-varying wave impedance approach for transparency compensation in bilateral teleoperation," in *Intelligent Robots and Systems, 2009. IROS 2009. IEEE/RSJ International Conference on*, Oct 2009, pp. 4609–4615.
- [157] H. Li and K. Kawashima, "Achieving stable tracking in wave-variable-based teleoperation," *Mechatronics, IEEE/ASME Transactions on*, vol. 19, no. 5, pp. 1574–1582, Oct 2014.
- [158] C. Zhang and K. T. Chong, "Passive bilateral teleoperation via the internet," in *SICE-ICASE, 2006. International Joint Conference*, Oct 2006, pp. 3072–3078.
- [159] S. Ganjefar, H. Momeni, and F. Janabi-Sharifi, "Teleoperation systems design using augmented wave-variables and smith predictor method for reducing time-delay effects," in *Intelligent Control, 2002. Proceedings of the 2002 IEEE International Symposium on*, 2002, pp. 333–338.
- [160] Y. Yokokohji, T. Tsujioka, and T. Yoshikawa, "Bilateral control with time-varying delay including communication blackout," in *Haptic Interfaces for Virtual Environment and Teleoperator Systems, 2002. HAPTICS 2002. Proceedings. 10th Symposium on*, 2002, pp. 285–292.
- [161] S. Yoo and K. Chong, "Adaptive wave variables for bilateral teleoperation using neural networks," *Neural Computing and Applications*, vol. 25, no. 6, pp. 1249–1262, 2014. [Online]. Available: <http://dx.doi.org/10.1007/s00521-014-1606-0>
- [162] S. Munir and W. Book, "Internet based teleoperation using wave variables with prediction," in *Advanced Intelligent Mechatronics, 2001. Proceedings. 2001 IEEE/ASME International Conference on*, vol. 1, 2001, pp. 43–50 vol.1.
- [163] E. Mujcic and A. Oravecic, "Correction of position error in internet-based teleoperation," in *Telecommunications Forum (TELFOR), 2012 20th*, Nov 2012, pp. 115–118.
- [164] N. Chopra, M. Spong, R. Ortega, and N. Barabanov, "On tracking performance in bilateral teleoperation," *Robotics, IEEE Transactions on*, vol. 22, no. 4, pp. 861–866, Aug 2006.
- [165] C. Secchi, S. Stramigioli, and C. Fantuzzi, "Compensation of position errors in passivity based teleoperation over packet switched communication networks," in *Proceedings of the 17th World Congress The International Federation of Automatic Control. IFAC*, July 2008, pp. 15 648–15 653. [Online]. Available: <http://doc.utwente.nl/64881/>
- [166] E. Nuno, L. Basanez, and R. Ortega, "Passive bilateral teleoperation framework for assisted robotic tasks," in *Robotics and Automation, 2007 IEEE International Conference on*, April 2007, pp. 1645–1650.
- [167] A. F. Villaverde, A. Barreiro, and C. Raimondez, "Passive position error correction in internet-based teleoperation," *Automatica*, vol. 46, no. 11, pp. 1884 – 1890, 2010. [Online]. Available: <http://www.sciencedirect.com/science/article/pii/S0005109810003456>
- [168] B. Hannaford and J.-H. Ryu, "Time-domain passivity control of haptic interfaces," *Robotics and Automation, IEEE Transactions on*, vol. 18, no. 1, pp. 1–10, Feb 2002.
- [169] J.-H. Ryu, D.-S. Kwon, and B. Hannaford, "Stable teleoperation with time-domain passivity control," *Robotics and Automation, IEEE Transactions on*, vol. 20, no. 2, pp. 365–373, April 2004.
- [170] J.-H. Ryu, J. Artigas, and C. Preusche, "A passive bilateral control scheme for a teleoperator with time-varying communication delay," *Mechatronics*, vol. 20, no. 7, pp. 812 – 823, 2010, special Issue on Design and Control Methodologies in Telerobotics. [Online]. Available: <http://www.sciencedirect.com/science/article/pii/S0957415810001303>
- [171] C. Preusche, G. Hirzinger, J.-H. Ryu, and B. Hannaford, "Time domain passivity control for 6 degrees of freedom haptic displays," in *Intelligent Robots and Systems, 2003. (IROS 2003). Proceedings. 2003 IEEE/RSJ International Conference on*, vol. 3, Oct 2003, pp. 2944–2949 vol.3.
- [172] H. Li, K. Tadano, and K. Kawashima, "Model-based passive bilateral teleoperation with time delay," *Transactions of the Institute of Measurement and Control*, vol. 36, no. 8, pp. 1010–1023, 2014. [Online]. Available: <http://tim.sagepub.com/content/36/8/1010.abstract>
- [173] J.-P. Kim and J. Ryu, "Robustly stable haptic interaction control using an energy-bounding algorithm," *The International Journal of Robotics Research*, vol. 29, no. 6, pp. 666–679, 2010. [Online]. Available: <http://ijr.sagepub.com/content/29/6/666.abstract>
- [174] L. Marton, J. Esclusa, P. Haller, and T. Vajda, "Passive bilateral teleoperation with bounded control signals," in *Industrial Informatics (INDIN), 2013 11th IEEE International Conference on*, July 2013, pp. 337–342.
- [175] Y. Hou and G. Luecke, "Time delayed teleoperation system control, a passivity-based method," in *Advanced Robotics, 2005. ICAR '05. Proceedings., 12th International Conference on*, July 2005, pp. 796–802.
- [176] X. Xu, B. Cizmeci, C. Schuwerk, and E. Steinbach, "Haptic data reduction for time-delayed teleoperation using the time domain passivity approach," in *IEEE World Haptics Conference, Chicago, USA*, Jun 2015.
- [177] J. Rebelo and A. Schiele, "Time domain passivity controller for 4-channel time-delay bilateral teleoperation," *Haptics, IEEE Transactions on*, vol. 8, no. 1, pp. 79–89, Jan 2015.
- [178] J. Artigas, J.-H. Ryu, C. Preusche, and G. Hirzinger, "Network representation and passivity of delayed teleoperation systems," in *Intelligent Robots and Systems (IROS), 2011 IEEE/RSJ International Conference on*, Sept 2011, pp. 177–183.
- [179] J.-H. Ryu, D.-S. Kwon, and B. Hannaford, "Stability guaranteed control: time domain passivity approach," *Control Systems Technology, IEEE Transactions on*, vol. 12, no. 6, pp. 860–868, Nov 2004.
- [180] H. V. Quang, I. Farkhatdinov, and J.-H. Ryu, "Passivity of delayed bilateral teleoperation of mobile robots with ambiguous causalities: Time domain passivity approach," in *Intelligent Robots and Systems (IROS), 2012 IEEE/RSJ International Conference on*, Oct 2012, pp. 2635–2640.
- [181] V. Chawda and M. OMalley, "Position synchronization in bilateral teleoperation under time-varying communication delays," *Mechatronics, IEEE/ASME Transactions on*, vol. 20, no. 1, pp. 245–253, Feb 2015.
- [182] S. Hirche and M. Buss, "Human-oriented control for haptic teleoperation," *Proceedings of the IEEE*, vol. 100, no. 3, pp. 623–647, March 2012.
- [183] P. Mitra and G. Niemeyer, "Model-mediated telemanipulation," *The International Journal of Robotics Research*, vol. 27, no. 2, pp. 253–262, 2008. [Online]. Available: <http://ijr.sagepub.com/content/27/2/253.abstract>
- [184] C. Passenberg, A. Peer, and M. Buss, "Model-mediated teleoperation for multi-operator multi-robot systems," in *Intelligent Robots and Systems (IROS), 2010 IEEE/RSJ International Conference on*, Oct 2010, pp. 4263–4268.
- [185] B. Willaert, H. Van Brussel, and G. Niemeyer, "Stability of model-mediated teleoperation: Discussion and experiments," in *Haptics: Perception, Devices, Mobility, and Communication*, ser. Lecture Notes in Computer Science, P. Isokoski and J. Springare, Eds. Springer Berlin Heidelberg, 2012, vol. 7282, pp. 625–636. [Online]. Available: http://dx.doi.org/10.1007/978-3-642-31401-8_55
- [186] X. Xu, C. Schuwerk, and E. Steinbach, "Passivity-based model updating for model-mediated teleoperation," in *Multimedia Expo Workshops (ICMEW), 2015 IEEE International Conference on*, June 2015, pp. 1–6.
- [187] L. Love and W. Book, "Force reflecting teleoperation with adaptive impedance control," *Systems, Man, and Cybernetics, Part B: Cybernetics, IEEE Transactions on*, vol. 34, no. 1, pp. 159–165, Feb 2004.
- [188] L. Huijun and S. Aiguo, "Virtual-environment modeling and correction for force-reflecting teleoperation with time delay," *Industrial Electronics, IEEE Transactions on*, vol. 54, no. 2, pp. 1227–1233, April 2007.
- [189] N. Diolaiti, C. Melchiorri, and S. Stramigioli, "Contact impedance estimation for robotic systems," *Robotics, IEEE Transactions on*, vol. 21, no. 5, pp. 925–935, Oct 2005.
- [190] A. Haddadi and K. Hashtrudi-Zaad, "A new method for online parameter estimation of hunt-crossley environment dynamic models," in *Intelligent Robots and Systems, 2008. IROS 2008. IEEE/RSJ International Conference on*, Sept 2008, pp. 981–986.
- [191] X. Xu and E. Steinbach, "Towards real-time modeling and haptic rendering of deformable objects for point cloud-based model-mediated teleoperation," in *Multimedia and Expo Workshops (ICMEW), 2014 IEEE International Conference on*, July 2014, pp. 1–6.
- [192] X. Xu, S. Chen, and E. Steinbach, "Model-mediated teleoperation for movable objects: Dynamics modeling and packet rate reduction," in *14th IEEE International Symposium on Haptic Audio-Visual Environments and Games*, Ottawa, Canada, Oct 2015.
- [193] H. Jin-quan and F. Lewis, "Neural-network predictive control for nonlinear dynamic systems with time-delay," *Neural Networks, IEEE Transactions on*, vol. 14, no. 2, pp. 377–389, Mar 2003.
- [194] A. Smith and K. Hashtrudi-Zaad, "Neural network-based teleoperation using smith predictors," in *Mechatronics and Automation, 2005 IEEE International Conference*, vol. 3, 2005, pp. 1654–1659 Vol. 3.

- [195] P. Prekopiou, S. Tzafestas, and W. Harwin, "Towards variable-time-delays-robust telemanipulation through master state prediction," in *Advanced Intelligent Mechatronics, 1999. Proceedings. 1999 IEEE/ASME International Conference on*, 1999, pp. 305–310.
- [196] I. B. France, "Predictive algorithms for distant touching," 2002.
- [197] C. Weber, V. Nitsch, U. Unterhinninghofen, B. Farber, and M. Buss, "Position and force augmentation in a telepresence system and their effects on perceived realism," in *EuroHaptics conference, 2009 and Symposium on Haptic Interfaces for Virtual Environment and Teleoperator Systems. World Haptics 2009. Third Joint*, March 2009, pp. 226–231.
- [198] D. Verscheure, J. Swevers, H. Bruyninckx, and J. De Schutter, "Online identification of contact dynamics in the presence of geometric uncertainties," in *Robotics and Automation, 2008. ICRA 2008. IEEE International Conference on*, May 2008, pp. 851–856.
- [199] S. Clarke, G. Schillhuber, M. Zaeh, and H. Ulbrich, "Telepresence across delayed networks: a combined prediction and compression approach," in *Haptic Audio Visual Environments and their Applications, 2006. HAVE 2006. IEEE International Workshop on*, Nov 2006, pp. 171–175.
- [200] X. Xu, B. Cizmeci, A. Al-Nuaimi, and E. Steinbach, "Point cloud-based model-mediated teleoperation with dynamic and perception-based model updating," *Instrumentation and Measurement, IEEE Transactions on*, vol. 63, no. 11, pp. 2558–2569, Nov 2014.
- [201] B. Willaert, J. Bohg, H. Van Brussel, and G. Niemeyer, "Towards multi-dof model mediated teleoperation: Using vision to augment feedback," in *Haptic Audio Visual Environments and Games (HAVE), 2012 IEEE International Workshop on*, Oct 2012, pp. 25–31.
- [202] Z. Zeinaly, A. Ramezani, and S. Ozgoli, "Robust stability for bilateral teleoperation systems under time-varying delay by communication disturbance observer," in *2014 Second RSI/ISM International Conference on Robotics and Mechatronics (ICRoM)*, Oct 2014, pp. 143–148.
- [203] K. Natori, R. Kubo, and K. Ohnishi, "Effects of controller parameters on transparency of time delayed bilateral teleoperation systems with communication disturbance observer," in *2008 IEEE International Symposium on Industrial Electronics*, June 2008, pp. 1287–1292.
- [204] A. Suzuki and K. Ohnishi, "Novel four-channel bilateral control design for haptic communication under time delay based on modal space analysis," *Control Systems Technology, IEEE Transactions on*, vol. 21, no. 3, pp. 882–890, May 2013.
- [205] T. Tashiro, T. Mizoguchi, T. Shimono, and K. Ohnishi, "Time delay compensation for dob-based contact force control under time delay," in *2017 IEEE International Conference on Mechatronics (ICM)*, Feb 2017, pp. 214–219.
- [206] J. S. Lee, T.-C. Chien, D. H. Jian, and Y. H. Sun, "A comparative study of communication disturbance observers for time-delay systems," in *2014 9th IEEE Conference on Industrial Electronics and Applications*, June 2014, pp. 616–620.
- [207] A. Jafari, M. Nabeel, and J.-H. Ryu, "Stable bilateral teleoperation with input-to-state stable approach," in *2015 IEEE/RSJ International Conference on Intelligent Robots and Systems (IROS 2015), Hamburg, Germany*, 2015.
- [208] A. Jafari, M. Nabeel, H. Singh, and J.-H. Ryu, "Stable and transparent teleoperation over communication time-delay: Observer-based input-to-state stable approach," in *IEEE Haptics Symposium 2016*, 2016.
- [209] R. Uddin and J. Ryu, "Predictive control approaches for bilateral teleoperation," *Annual Reviews in Control*, vol. 42, pp. 82 – 99, 2016. [Online]. Available: <http://www.sciencedirect.com/science/article/pii/S136757881630089X>
- [210] S. Hirche and M. Buss, "Transparent data reduction in networked telepresence and teleaction systems. part ii: Time-delayed communication," *Presence: Teleoperators and Virtual Environments*, vol. 16, no. 5, pp. 532–542, Sep 2007. [Online]. Available: <http://dx.doi.org/10.1162/pres.16.5.532>
- [211] I. Victorias, J. Kammerl, S. Hirche, and E. Steinbach, "Perceptual coding of haptic data in time-delayed teleoperation," in *EuroHaptics conference, 2009 and Symposium on Haptic Interfaces for Virtual Environment and Teleoperator Systems. World Haptics 2009. Third Joint*, March 2009, pp. 208–213.
- [212] M. A. Lema, A. Laya, T. Mahmoodi, M. Cuevas, J. Sachs, J. Markendahl, and M. Dohler, "Business case and technology analysis for 5g low latency applications," *CoRR*, vol. abs/1703.09434, 2017. [Online]. Available: <http://arxiv.org/abs/1703.09434>
- [213] J. Huang, F. Qian, A. Gerber, Z. M. Mao, S. Sen, and O. Spatscheck, "A close examination of performance and power characteristics of 4g lte networks," in *Proceedings of the 10th International Conference on Mobile Systems, Applications, and Services*, ser. MobiSys '12. New York, NY, USA: ACM, 2012, pp. 225–238. [Online]. Available: <http://doi.acm.org/10.1145/2307636.2307658>
- [214] 3GPP, "Feasibility study on new services and markets technology enablers for critical communications; stage 1," 3GPP, Tech. Rep., October 2016, TR 22.862, Release 14.
- [215] —, "Study on new services and markets technology enablers," 3GPP, Tech. Rep., September 2016, TR 22.891, Release 14.
- [216] T. Mahmoodi and S. Seetharaman, "Traffic jam: Handling the increasing volume of mobile data traffic," *IEEE Vehicular Technology Magazine*, vol. 9, no. 3, pp. 56–62, Sept 2014.
- [217] —, "On Using a SDN-based Control Plane in 5G Mobile Networks," in *Wireless World Research Forum, 32nd Meeting*, May 2014.
- [218] A. C. Morales, A. Aijaz, and T. Mahmoodi, "Taming Mobility Management Functions in 5G: Handover Functionality as a Service (FaaS)," in *IEEE Global Communications Conference (GLOBECOM)*, Dec 2015.
- [219] M. Amani, T. Mahmoodi, M. Tatipamula, and H. Aghvami, "Programmable policies for Data Offloading in LTE Network," in *IEEE International Conference on Communications (ICC)*, June 2014.
- [220] —, "SDN-based Data Offloading for 5G Mobile Networks," *ZTE Communications*, no. 2, July 2014.
- [221] I. Giannoulakis, E. Kafetzakis, G. Xylouris, G. Gardikis, and A. Kourtis, "On the applications of efficient nfV management towards 5g networking," in *1st International Conference on 5G for Ubiquitous Connectivity*, Nov 2014, pp. 1–5.
- [222] S. Shorgin, K. Samouylov, I. Gudkova, O. Galina, and S. Andreev, "On the benefits of 5g wireless technology for future mobile cloud computing," in *Science and Technology Conference (Modern Networking Technologies) (MoNeTeC), 2014 International*, Oct 2014, pp. 1–4.
- [223] A. A. Dyumin, L. A. Puzikov, M. M. Rovnyagin, G. A. Urvanov, and I. V. Chugunkov, "Cloud computing architectures for mobile robotics," in *Young Researchers in Electrical and Electronic Engineering Conference (EICoN RusNW), 2015 IEEE NW Russia*, Feb 2015, pp. 65–70.
- [224] E. Shin and G. Jo, "Uplink frame structure of short tti system," in *2017 19th International Conference on Advanced Communication Technology (ICACT)*, Feb 2017, pp. 827–830.
- [225] "Utilizing massive mimo for the tactile internet: Advantages and trade-offs," in *IEEE SECON Workshops - Robotic Wireless Networks*. IEEE–Institute of Electrical and Electronics Engineers Inc., 2017.
- [226] M. A. Lema, T. Mahmoodi, and M. Dohler, "On the Performance Evaluation of Enabling Architectures for Uplink and Downlink Decoupled Networks," in *IEEE Global Communications Conference (GLOBECOM) Workshops*, December 2016.
- [227] A. Aijaz, "Towards 5g-enabled tactile internet: Radio resource allocation for haptic communications," in *2016 IEEE Wireless Communications and Networking Conference*, April 2016, pp. 1–6.
- [228] M. Condoluci, T. Mahmoodi, E. Steinbach, and M. Dohler, "Soft resource reservation for low-delayed teleoperation over mobile networks," *IEEE Access*, vol. 5, pp. 10 445–10 455, 2017.
- [229] L. Girish and S. K. N. Rao, "Mathematical tools and methods for analysis of sdn: A comprehensive survey," in *2016 2nd International Conference on Contemporary Computing and Informatics (IC3I)*, Dec 2016, pp. 718–724.
- [230] N. Bui, M. Cesana, S. A. Hosseini, Q. Liao, I. Malanchini, and J. Widmer, "A survey of anticipatory mobile networking: Context-based classification, prediction methodologies, and optimization techniques," *IEEE Communications Surveys Tutorials*, vol. 19, no. 3, pp. 1790–1821, thirdquarter 2017.
- [231] D. Szabo, A. Gulyas, F. H. Fitzek, F. H. Fitzek, and D. E. Lucani, "Towards the tactile internet: Decreasing communication latency with network coding and software defined networking," in *European Wireless 2015; 21th European Wireless Conference; Proceedings of*, May 2015, pp. 1–6.
- [232] ITU, "ITU-T technology watch report: Tactile internet," 2014. [Online]. Available: <http://www.itu.int/oth/T2301000023/en>



Konstantinos Antonakoglou is currently an MPhil/PhD student at the Department of Informatics, King's College London. He holds a B.Sc. degree in Electronics Engineering from Technological Educational Institute (TEI) of Piraeus and an M.Sc. in Electronic Automation from National and Kapodistrian University of Athens (NKUA). His current research interests include haptic communication and QoS/QoE in mobile networks for multi-modal media.



Xiao Xu (IEEE M11) received the B.Sc. degree in information engineering from Shanghai Jiao Tong University, China, in 2008, and the M.Sc. degree in information engineering from the Technical University of Munich (TUM), Germany, in 2011. After this, he joined the Chair of Media Technology, TUM, in April 2011, where he worked as a member of the Research Staff. His research interests were in the field of perceptual coding of haptic data streams with stability ensuring control architectures and the model-mediated telemanipulation. He received the

Ph.D. degree in June 2017. From December 2017 he joined the Altran Technologies, SA (Germany) as an advanced consultant, where he worked as a group leader for the pre-development of autonomous-driving technologies. From March 2018 he joined the Chair of Media Technology, TUM, where he is working as a senior researcher with the research interests of haptic codecs and haptic communications.



Eckehard Steinbach (IEEE M'96, SM'08, F'15) studied Electrical Engineering at the University of Karlsruhe (Germany), the University of Essex (Great-Britain), and ESIEE in Paris. From 1994 - 2000 he was a member of the research staff of the Image Communication Group at the University of Erlangen-Nuremberg (Germany), where he received the Engineering Doctorate in 1999. From February 2000 to December 2001 he was a Postdoctoral Fellow with the Information Systems Laboratory of Stanford University. In February 2002 he joined

the Department of Electrical and Computer Engineering of the Technical University of Munich (Germany), where he is currently a Full Professor for Media Technology. His current research interests are in the area of audio-visual-haptic information processing and communication as well as networked and interactive multimedia systems.



Toktam Mahmoodi received the B.Sc. degree in electrical engineering from the Sharif University of Technology, Iran, and the Ph.D. degree in telecommunications from Kings College London, U.K. She was a Visiting Research Scientist with F5 Networks, San Jose, CA, in 2013, a Post-Doctoral Research Associate with the ISN Research Group, Electrical and Electronic Engineering Department, Imperial College from 2010 to 2011, and a Mobile VCE Researcher from 2006 to 2009. She has also worked

in mobile and personal communications industry from 2002 to 2006, and in an R&D team on developing DECT standard for WLL applications. She has contributed to, and led number of FP7, H2020 and EPSRC funded projects, advancing mobile and wireless communication networks. Toktam is currently with the academic faculty of Centre for Telecommunications Research at the Department of Informatics, Kings College London. Her research interests include 5G communications, network virtualization, and low latency networking.



Mischa Dohler (S99M03SM07F14) is full Professor in Wireless Communications at Kings College London, driving cross-disciplinary research and innovation in technology, sciences and arts. He is a Fellow of the IEEE, the Royal Academy of Engineering, the Royal Society of Arts (RSA), the Institution of Engineering and Technology (IET); and a Distinguished Member of Harvard Square Leaders Excellence. He is a serial entrepreneur; composer & pianist with 5 albums on Spotify/iTunes; and fluent in 6 languages.

He acts as policy advisor on issues related to digital, skills and education. He has had ample coverage by national and international press and media. He is a frequent keynote, panel and tutorial speaker, and has received numerous awards. He has pioneered several research fields, contributed to numerous wireless broadband, IoT/M2M and cyber security standards, holds a dozen patents, organized and chaired numerous conferences, was the Editor-in-Chief of two journals, has more than 200 highly-cited publications, and authored several books. He was the Director of the Centre for Telecommunications Research at Kings from 2014-2018. He is the Cofounder of the Smart Cities pioneering company Worldensing, where he was the CTO from 2008-2014. He also worked as a Senior Researcher at Orange/France Telecom from 2005-2008.